

OMEA “All Sky” Camera

Installation and user manual

April 20th, 2026 revision



Table of Contents

| | | |
|-------|--|----|
| 1 | Camera installation | 4 |
| 1.1 | Camera installation..... | 4 |
| 1.2 | Connectors for camera delivered before Sept 2024 (serial number 127977) | 6 |
| 1.3 | Connectors for camera delivered after Sept 2024 (serial number 127977) | 10 |
| 1.4 | Guidelines for cable installation to decrease lightning strike damages..... | 12 |
| 1.5 | Camera optical settings | 14 |
| 1.6 | OMEA camera connections (USB version) before SNR 127977..... | 15 |
| 1.6.1 | Temperature sensor and humidity connector (#1)..... | 16 |
| 1.6.2 | Power connector and RS232 (#2)..... | 16 |
| 1.6.3 | USB connector (#3) | 19 |
| 1.7 | OMEA camera connections (ETHERNET version) before SNR 127977 | 20 |
| 1.8 | OMEA camera connections with External Weather Module | 22 |
| 1.9 | Camera stand..... | 22 |
| 2 | Software..... | 24 |
| 2.1 | System requirement and operating system | 24 |
| 2.2 | Camera installation software | 24 |
| 2.3 | Embedded Ethernet camera software installation | 28 |
| 3 | Using the camera software control | 35 |
| 3.1 | Initializing..... | 35 |
| 3.1.1 | All cameras type..... | 35 |
| 3.1.2 | OMEA 8x/7x/9x specific initialization phases | 36 |
| 3.1.3 | Camera setup | 39 |
| 3.1.4 | OMEA 8x/7x/9x cooling setup..... | 41 |
| 3.1.5 | Exposure control | 43 |
| 3.2 | Storage of files produced by the camera control software..... | 44 |
| 3.3 | Camera exposure time and gain..... | 46 |
| 3.3.1 | Manual mode | 46 |
| 3.3.2 | Automatic mode..... | 46 |
| 3.4 | Image hot pixel removal using dark frame image | 47 |
| 3.4.1 | Achieving master dark frame | 51 |
| 3.4.2 | Residual hot pixels repair/fix..... | 53 |
| 3.5 | Setting the overlay grid | 55 |
| 3.6 | Cyanogen Boldwood or Sentinel cloud sensors link with camera control software..... | 58 |
| 3.7 | Magnitude per square second display image mode | 59 |
| 3.8 | Telescope control software link | 61 |

| | | |
|------|--|----|
| 3.9 | Star count for cloud coverage estimation | 61 |
| 3.10 | 24h overview | 62 |
| 4 | Sphere condensation heater management | 65 |
| 4.1 | Introduction | 65 |
| 4.2 | Adjusting and start-up | 65 |
| 5 | Weather measurement module | 69 |
| 5.1 | Sensors software management | 72 |
| 5.2 | Sensor specifications and operating range..... | 74 |
| 6 | Camera maintenance | 75 |
| 6.1 | Sphere cleaning | 75 |
| 6.2 | Camera internal desiccant replacement | 75 |
| 7 | Trouble shooting | 75 |
| 7.1 | Camera does not deliver images | 75 |
| 7.2 | Camera disconnects when heating is active..... | 75 |
| 7.3 | Dew inside the dome..... | 77 |
| 8 | Product terms of use..... | 77 |

List of applicable products of this documentation

| |
|----------------|
| OMEA 6M |
| OMEA 6C |
| OMEA 3M |
| OMEA 3C |
| OMEA 5M |
| OMEA 5C |
| OMEA 8M |
| OMEA 8C |
| OMEA 9M |
| OMEA 9C |
| OMEA 7C |
| OMEA 7M |

1 Camera installation

1.1 Camera installation

The camera works outdoor, it is weather-tight. Warning, the system is not submersible: it is not a diving camera. Moreover, it will prevent all intrusion of insects, even the smallest one.

The camera has no mechanical shutter and Sun's heat does not cause loss of operation of the camera.

Please do not install the camera near a pollution source (like a chimney). Give as much exposure as possible and avoid obstacles.

It is advised to level the camera with respect to the ground.

The camera has three anchors on the back, these three ISO M6 not thru threaded holes by 10 mm depth. Use the supplied screws to fix or equivalent stainless steel A4 or A2 screw. The following stand can be used to install the camera safely (this is an optional item, purchased on request)



Fig. 1 *Optional stand for the camera*

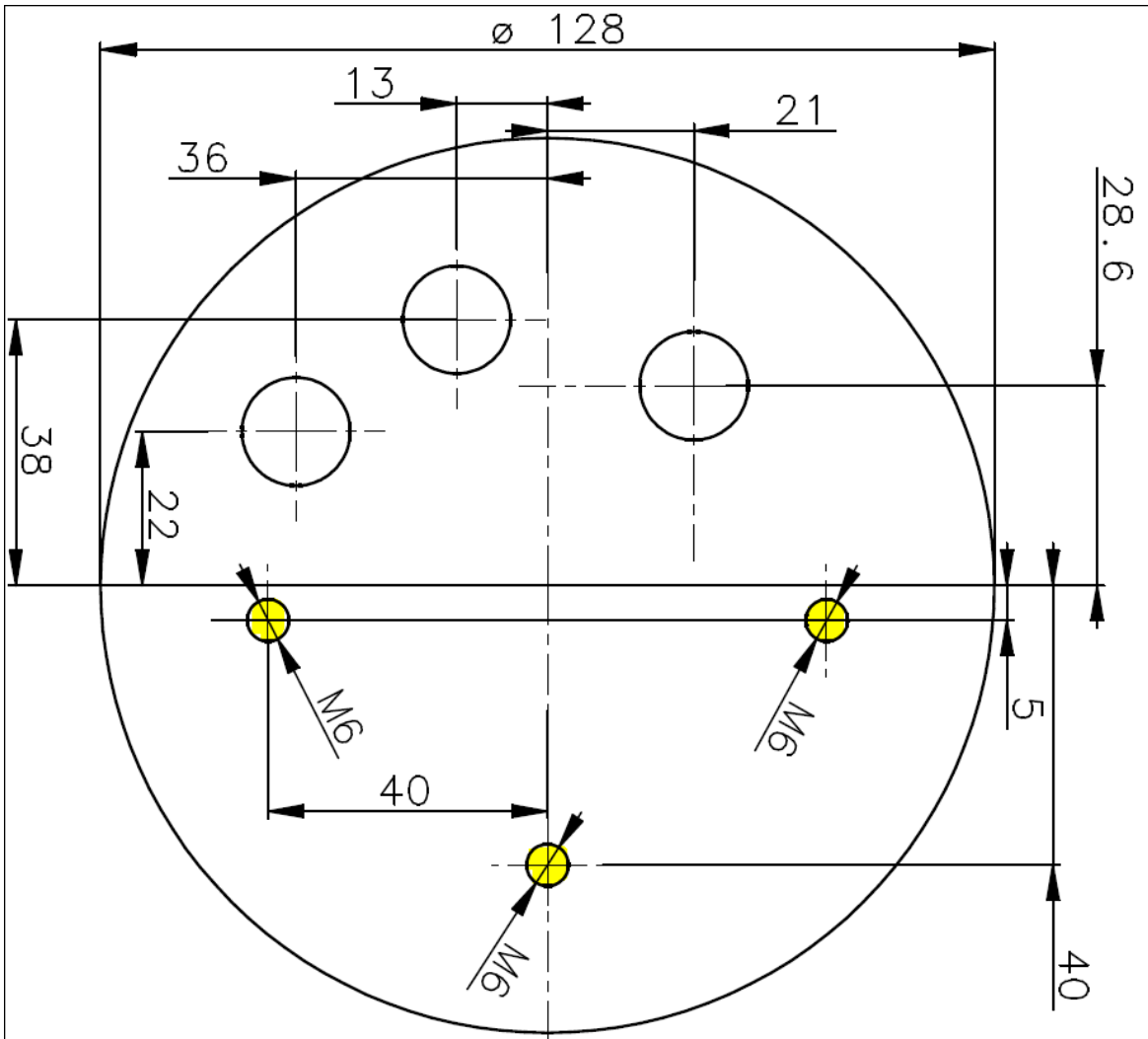

Fig. 2 *The position of the three screws securing the USB camera (yellow holes)*

There are three other "holes" that are filled with waterproof connectors, leave this space free and 100mm underneath to allow the cables to run.

The N, S, E and W direction is defined by rotating the camera accordingly. This is up to the user to define camera orientation according to its needs. Please perform image capture tests before attaching the camera to the pole.

The cables go straight from the camera bottom. If the cables shall be bent, respect what is shown on the picture (Fig. 3)

For camera released after sept 2024, a new set of metallic connectors have been installed. Those connectors are M12 compliant.

1.2 Connectors for camera delivered before Sept 2024 (serial number 127977)

These are plastic rubber Swichcraft brand connectors. Those are black and have no metallic parts.



Fig. 4 *Three cables straight descent.*

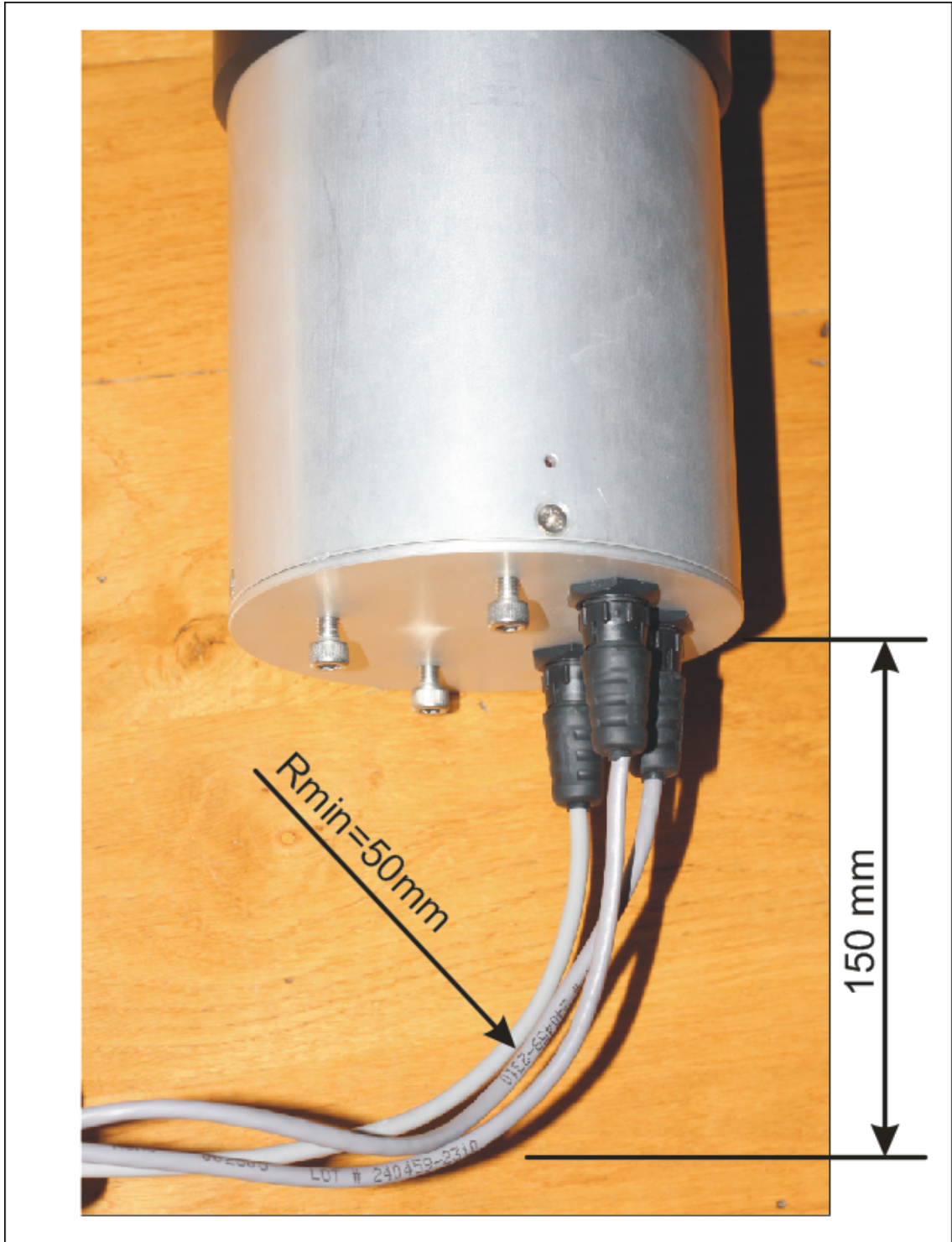

Fig. 5 *Minimum cable radius curvature.*

The waterproof connectors connect as follows:

- Identify the number of connector pins of the camera, its type (male / female)

- Identify the number of pins of the connector cord and match.
- Identify the key pin inside the camera connector and the key at the connector cord side.
- Apply a rectilinear motion. **If insertion force strength persists please repeat steps for locating the pin number and key. Excessive force applied to connector can cause the destruction of the connector or a bad connection can damage the camera. In case of damage due to trials to attach cable to the wrong connector kind, warranty could be canceled.**

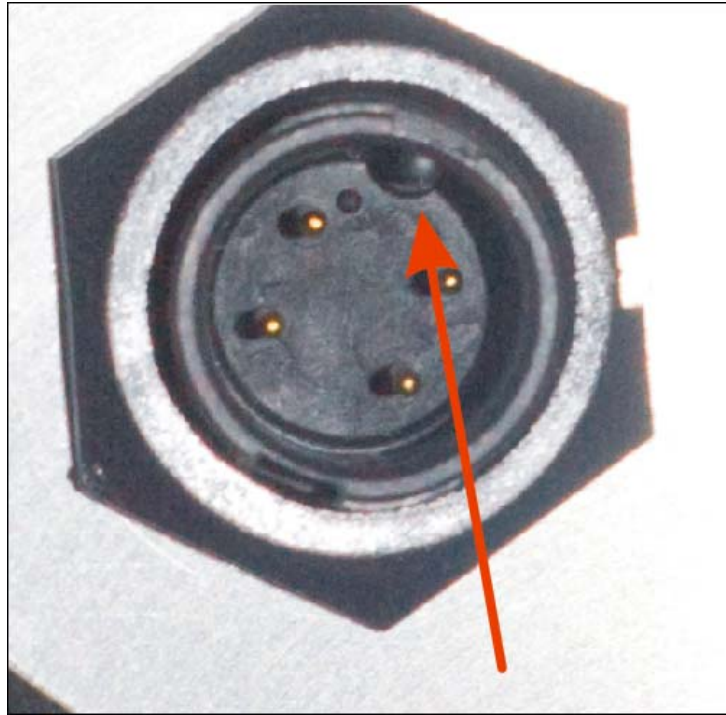

Fig. 6 Key one of the three connectors (power connector).



Fig. 7 Push the connector straight



Fig. 8 Then turn the connector's collar in clockwise fashion

1.3 Connectors for camera delivered after Sept 2024 (serial number 127977)

The 3 connectors are M12 type with 1 mm thread step. In this case, there are **threaded metal ring** in the camera and cable connectors (male/female). These connectors are not compliant with the previous version of the AllSky camera, meaning new version of cables cannot fit into the older connector and vice versa.

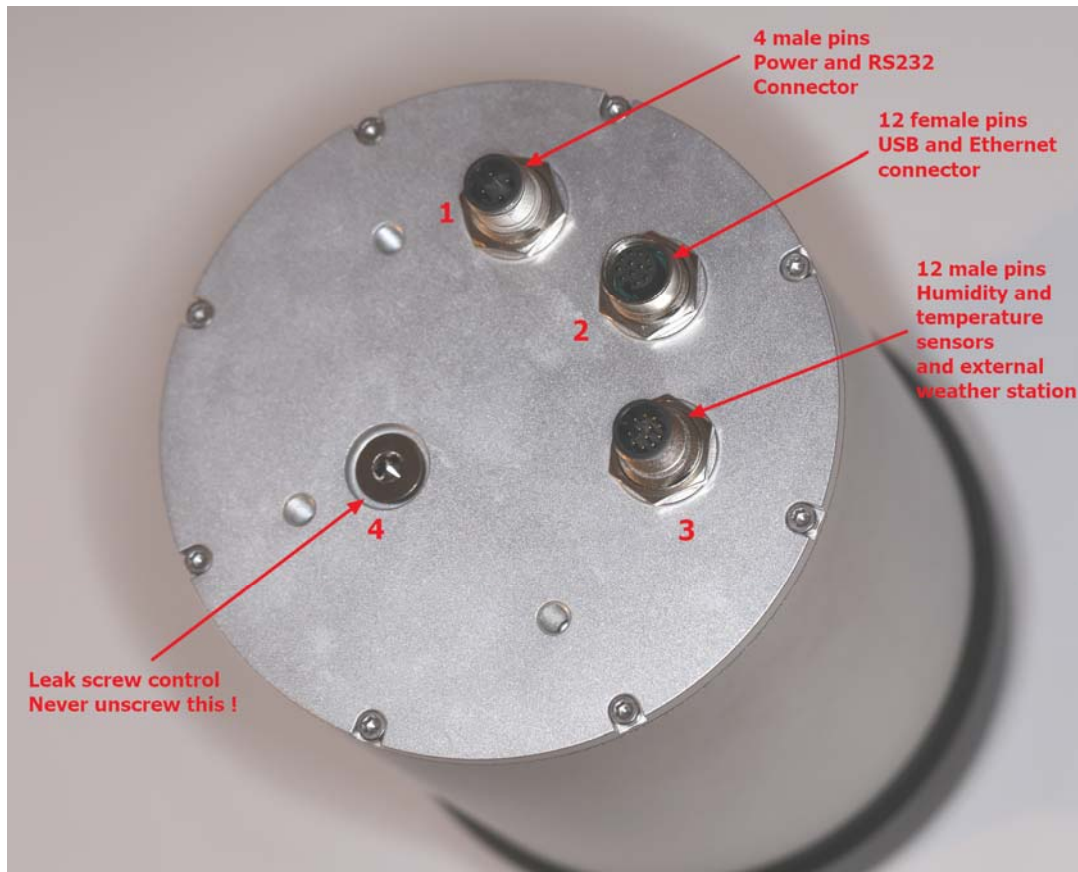

Fig. 9 New metal connectors located at camera backside

- Connector in position 1: this is for powering the camera with 24V voltage (2 pins) and the last 2 pins are serial RS232 signals (RX,TX) that comes from the internal weather and environment board. It has 4 pins in total. The weather and internal/external environmental signals are carried by this connector via serial protocol. No image data from the camera are using this connector.
- Connector in position 2: this connector is both for USB 2.0 and Ethernet link to computer. Warning those 2 options are mutually exclusive. If USB camera has been ordered it must come with special USB cable; if Ethernet camera has been ordered it must be delivered with dedicated ethernet cable. Camera does not have both mode available at the same time: internal routing at production stage determines the type of output. Camera image data are using this connector.

- Connector in position 3: this connector is either for humidity and temperature probe; or for complete weather station (wind speed, direction and pressure measurement). This latter is delivered on request and is not a standard feature.
- Screw in position 4: this is used during manufacturing tests, to check that there's no leak in the camera that could allow water to ingress inside the casing. **Never ever remove this screw.** Doing so can void the warranty, also humidity level is kept under 10% inside the camera thank to desiccant bag.

All connectors have a coding notch and cannot be swapped. Please pay attention to the notch position where to insert the cable. If the connector is not inserted properly, it will be impossible to screw / attach the cable to the camera.

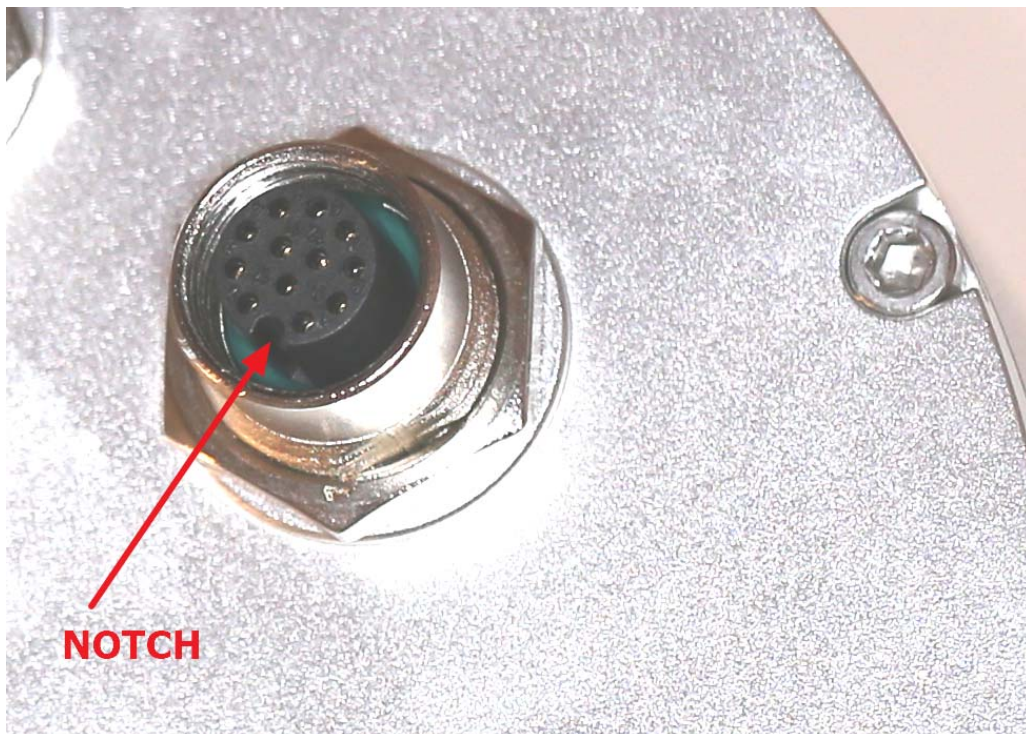

Fig. 10 All connectors have coding notch, please orientate the cable during insertion

Please follow those steps:

1. Spot the coding notch position and insert the cable connector in the orientation where it matches the camera connector. When achieved screwing action can be achieved. If not this is impossible to screw the cable connector to the camera connector.
2. Once inserted (green arrow) rotate the threaded ring so that the connector starts to catch the screw thread. You can put some grease to help out (only on threads, never on connector pins).
3. Rotate clockwise several turns till the thread has almost disappeared inside the cable connector ring. At some point, the tightening torque will be high and the ring will be

stuck to its final position. Failure to screw completely this connector can lead to operational failure and water to ingress inside the connector and damage it. No warranty will be granted for not having screw properly the connector.



Fig. 11 Spot the coding notch and push the cable connector, then rotate several turns to screw it.

1.4 Guidelines for cable installation to decrease lightning strike damages

Attention must be taken against thunderstorms and close-by lightning. If your site is prone to hits from lightning strikes and surge power, user shall pay attention to them. This might damage the 20m USB cable or the internal environment board (RS232 link). In rare case, this can destroy/damage also the camera image sensor electronic, that is very expensive to replace. As per our term and sales, this kind of damages are not covered by the warranty and our company has all the means to assess the cause of the damages. Care must be taken to insulate the camera from nearby lightnings and associated deleterious effects that can extend to a large range from ground impact.



Fig. 12 *Lightning strike extended damage area by induction effects*

It is strictly unadvised to coil/loop the USB or the power-RS232 cable because it is too long, like in the picture below. This can be convenient to reduce the footprint of the cables, but this can lead to disasters and failures.

When a lightning strike occurs, even, say, at up to 100m/200m from the camera, a huge magnetic field change is produced in a very short amount of time. The cable, put in coils, can turn into a voltage this magnetic field change, that will be directly multiplied by the number of cable loops. This is called induction (please read this https://en.wikipedia.org/wiki/Electromagnetic_induction for more info).

At the end of the cables, a voltage higher than 30 000 volts can be created and destroy all camera electronics or damage electronic boards, in a way that image data transfer from camera to the PC can be halted in a random fashion. It can be difficult to assess the root cause of loss of camera reliability. Our cameras are tested in factory outdoors during several days and can output several thousands of images without a single glitch (or missing image).

The document below can be read also

<https://arcca.com/wp-content/uploads/2018/07/When-Lightning-Strikes-How-Electrical-Devices-Are-Affected.pdf>



Fig. 13 **Avoid to coil the USB and Power cable this way,**
this increases greatly surge power and may destroy the camera

It is sometime a good advice to use services from an electrical company that can help to reduce the risk of lightning strikes damages by proper earthing/grounding schemes and surge protection. Sometime, fiber data link between the camera and the PC can be used to remove of induction damage risks.

1.5 Camera optical settings

1.2.1. OMEA 3x, 5x and OMEA 6x

The focus of the lens with respect to the image sensor is factory tuned. It is not possible to perform focus changes from outside, for tightness reasons.

F-number is fixed set to its lowest value, F1.6 allowing very sensitive operation of the camera. This cannot be changed from outside.

Sharpness may vary from center to edges, according to the lens design and lens manufacturing quality variations.

Opening the dome is possible, but this will jeopardize inner camera dryness: some desiccants bags are installed inside the camera, and if the dome is opened, those bags must be replaced!

Infrared light (>700 nm) is blocked. Pixel size is 2.2 μ m for OMEA 3x and OMEA 6x.

1.2.2. OMEA 7x, 8x and OMEA 9x

The tilt of the lens with respect to the image sensor is factory tuned. It is possible to perform focus changes remotely by using the RS232 link. ALCOR-SYSTEM will provide to the user the best focus encoder count (from 900 to 1100 encoders steps) Some variation may occur around this value during the life of the camera.

By the same link, F-number can be user selected. The lowest F/ is F2.8 and must be used overnight. During the day F/5.6 or F/8 can be used. This can be set by PC software.

Sharpness may vary from center to edges, according to the lens design and lens manufacturing quality variations.

Opening the dome is possible, but this will jeopardize inner camera dryness: some desiccants bags are installed inside the camera, and if the dome is opened, those bags must be replaced!

Infrared light (>680 nm) and UV light is blocked (<420 nm). Pixel size is 3.8µm.

1.6 OMEA camera connections (USB version) before SNR 127977

Connector's keying and different number of pins are preventing connection errors. However, user must look at the number of connector pins at the end of the cord before connecting the camera, in order to avoid forcing the pins and damage the camera connector.



Fig. 14 Rear of USB camera

| Connector | Role | Gender (camera side) |
|-----------|-------------------------------|----------------------|
| #1 | Temperature / Humidity sensor | Female 5 pins |

| | | |
|----|-----------------------------------|-------------|
| #1 | Weather station module (optional) | Male 7 pins |
| #2 | Power connector and RS232 link | Male 4 pins |
| #3 | USB link | Male 6 pins |

For more information about the pins of these connectors, please ask us.

If Weather module is present, never touch with your fingers the 7 pins of the connector (Connector #1).

1.6.1 Temperature sensor and humidity connector (#1)

It is a 5-pin connector. The probe located at the end of the cord will be placed preferably in the shade, as far as possible from the camera, **and always with two set Ø4mm screws with the direction given in the next frame and horizontally. It put upside down (or in the wrong side), this can destroy the sensor and warranty will not apply.**

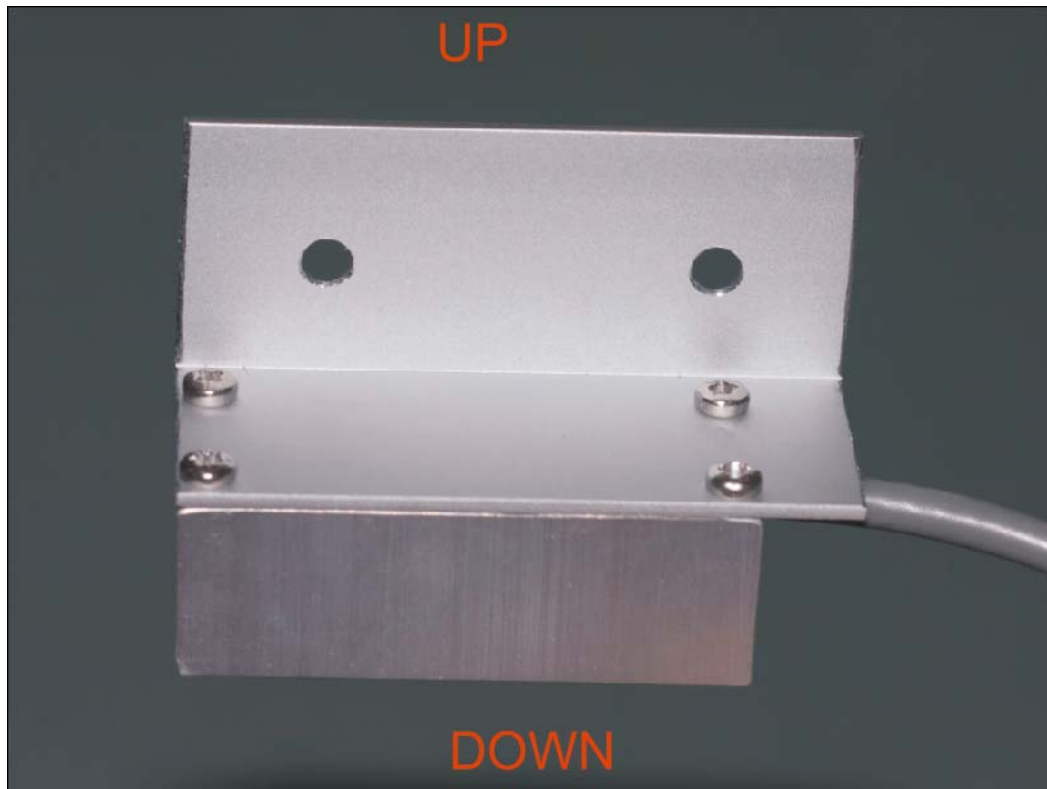

Fig. 15 up / down and horizontal temperature sensor and humidity directions for installation

This sensor is intended to provide outdoor temperature and relative humidity in order to automatically trigger dome heating, (only when weather conditions are prone to develop dew on the camera's dome).

1.6.2 Power connector and RS232 (#2)

This is providing power to the camera and RS232 link.

The RS232 connector is a DB9 connector type female and attaches to the serial port of the PC. New PCs are not equipped with serial port, and must be equipped either:

- By a RS232 – USB converter (very moderate cost, FTDI, ATEN devices)
- By RS232 PCI card (Low cost device, not suitable for laptops)
- By Serial to Ethernet (MOXA devices, http://www.moxa.com/product/nport_device_server_1.htm) Product type is Nport.



Fig. 16 RS232 connector and 24V 2.5A power

The power supply is provided as 24V 2.5A, 110V 60Hz and 220V 50Hz compliant. The current provided by the PSU is enough to power the camera and the dome heater. Three kind of cord plugs are provided on request: EU, US and UK type.

At the end of the RS232 cable, a USB to RS232 high quality converter is provided to the user, in order to ease camera installation. Once connected to the PC, the driver is loaded automatically for Windows 10. For other OS, please go here to pick up the proper driver:

<http://www.ftdichip.com/FTDrivers.htm>

Under windows 7, it will appear as UC232R in device manager and driver must appear as follows after driver installation (can be another COM number port).

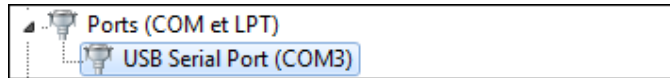

Fig. 17 Driver is installed and COM 3 port created

Under Windows 8, ask windows device manager to update this device from internet, and driver will be installed automatically.

Finally, it must be kept in mind that the PC, must have TWO USB port free for the system, one for the camera image data stream, and another for this RS232 to USB link. This RS232 data link is used to get:

- Weather information from the camera (outdoor temperature, outdoor relative humidity, inner camera temperature and humidity, dome heater temperature)
- Optional Weather station module information (wind speed, wind direction, atmospheric pressure ...)
- For OMEA 8x/9x/7x camera, the lens focus and iris can be set by this link.



Fig. 18 RS232 to USB converter

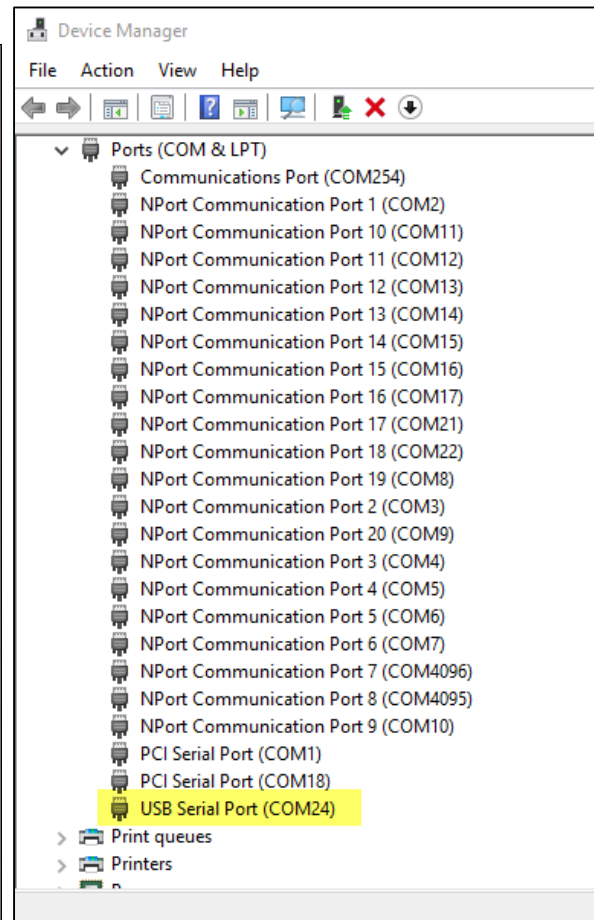

Fig. 19 COM port under Device manager, warning it can be another number than COM24 ...any number from 1 to 255

The device manager properties for this COM port should be seen as follows once connected:

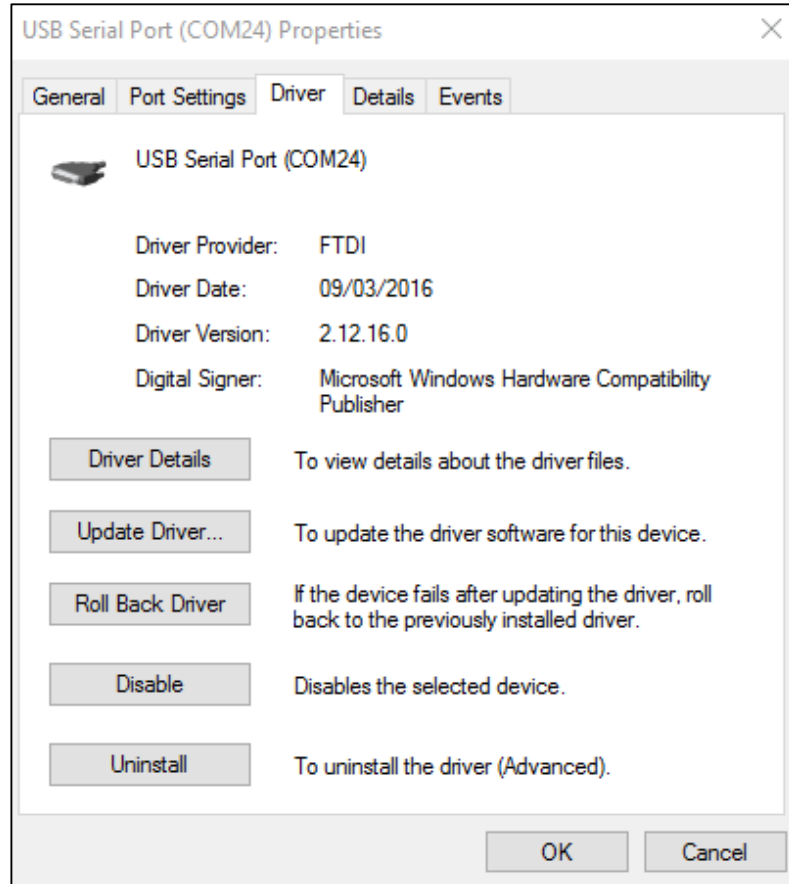

Fig. 20 Serial to USB converter, as it appears in the device manager

Always have the RS232 link connected to the camera in one side and to the PC in the other side. Failure to comply with this requirement will jeopardize camera operation and performance.

Keep somewhere the COM number, this is very important. In case of USB to RS232 converter, keep the converter in the same USB port, otherwise COM number will change.

1.6.3 USB connector (#3)

This is tied up to a 6 pin connector. Please always connect the camera first and then connect to PC second. The cable that goes to the PC is 20m length.

1.7 OMEA camera connections (ETHERNET version) before SNR 127977

This is the same as USB camera, except the USB 6 pins connector is replaced by 8 pins male connector. Also, the cable is different. It is a blue/cyan cable, that has in one side, 8 pin female connector and ethernet connector in the other side. Cable length is 20m

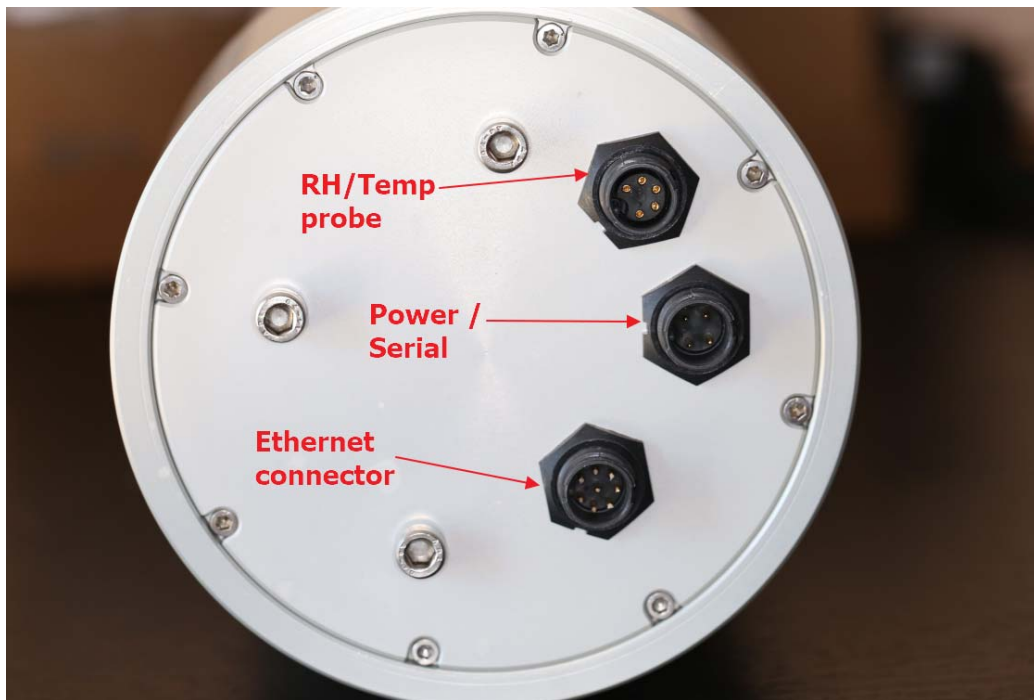

Fig. 21 : Ethernet camera backside

The camera contains/embeds a module called “Gigabit USB High Throughput Device Server” that converts the camera USB output into Ethernet link. The internal camera wiring uses USB 2.0 port, not USB 3.0

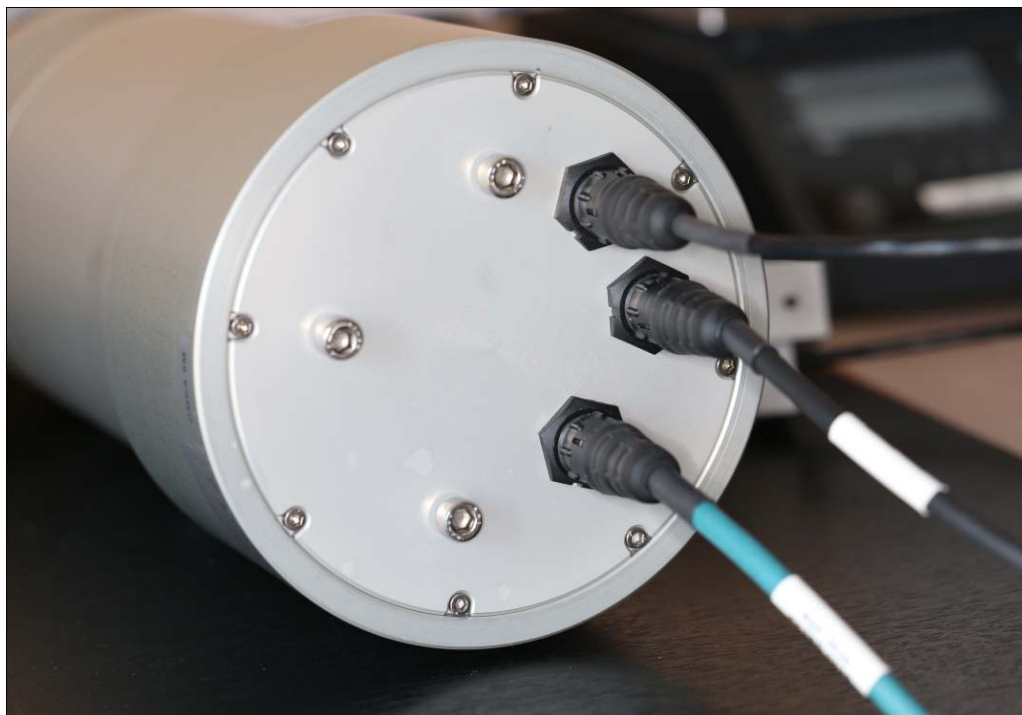

Fig. 22 Ethernet camera backside and cables connected

In the end, the host PC sees the camera as a regular USB device, despite data goes throughout ethernet cable.

The embedded Silex DS-600 is designed to easily connect and share USB 3.0 and 2.0 devices over a network. Printers, Scanners, Disk Drives, Cameras, Card Readers, or virtually any other USB device can be enabled with network capability. It allows flexibility to place the USB device anywhere on the network instead of needing to be attached directly to the computer, and multiple users can access the USB device. It helps extending the distance from the camera to the PC. Alcor-system did extensive tests that have proven good reliability of this device.

The Gigabit USB High Throughput Device Server has an IP address to communicate with.

NOTE: For Linux users, as date of June 2020, there is no free SDK to drive the camera throughout Ethernet to USB with this device server.

1.8 OMEA camera connections with External Weather Module

It very important to connect all the cables first, at the camera back plate, and then connect the 24V power supply in a second step. If not achieved in this order, this can damage the internal board of the camera or the weather board located in the additional external box. Also do not disconnect the external weather cable while the camera is powered. Failure to do so may void the warranty.

1.9 Camera stand

A camera can be provided as optional item. It is intended to be installed on a flat surface



Fig. 23 Picture of the camera support

Three screws of 8 mm maximum diameter of any type can be used to attach this stand to a fixed surface.



Fig. 24 Camera installed into a camera support

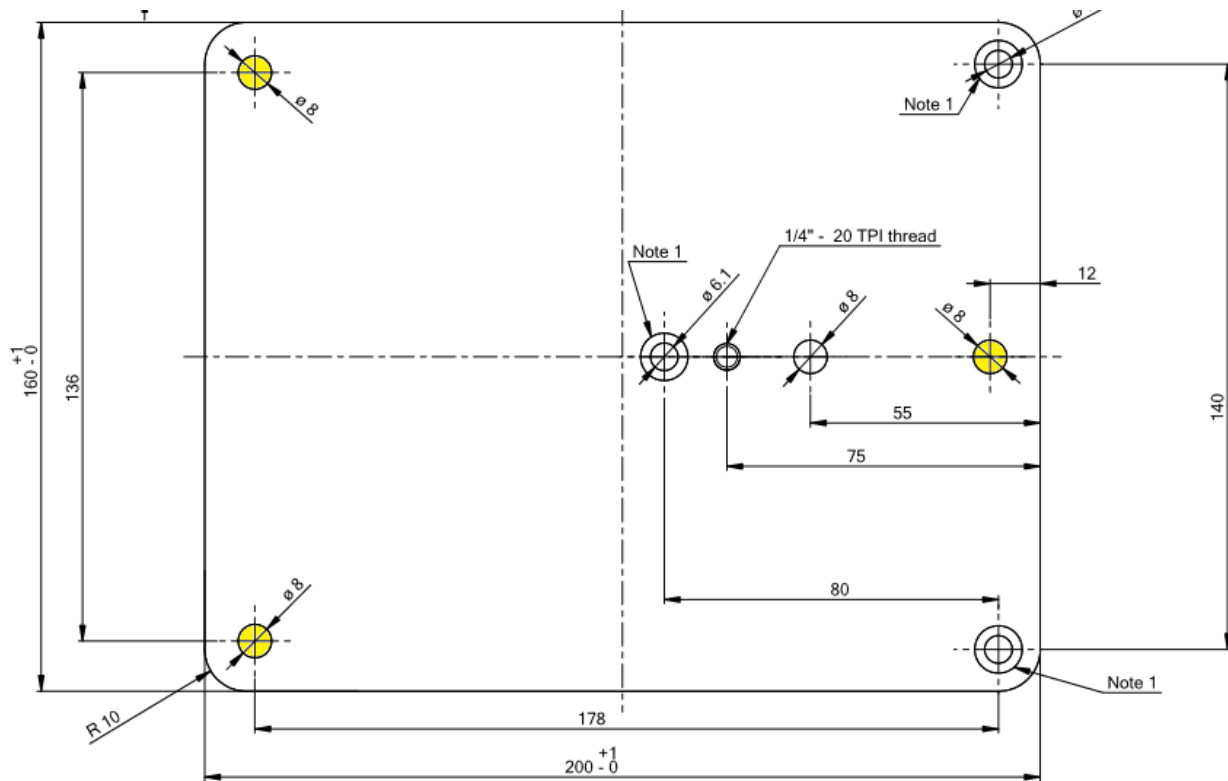

Fig. 25 Drawing of the base plate, yellow $\varnothing 8$ mm holes are intended to attach the support to wooden or concrete flat surface. This is an upside-down view.

2 Software

Latest camera software can be found in our web site:

https://www.alcor-system.com/common/allSky/sw/setup_skywatch.exe

2.1 System requirement and operating system

Hardware requirement (Minimum) OMEA 3x/6x

- PC with AMD or Intel CPU, (with passmark index above 2000)
 - Intel Core i3-4012Y @ 1.50GHz ([passmark index : 2000](#))

Hardware requirement (Minimum) OMEA 7/8/9x

- PC with AMD or Intel CPU, (with passmark index above 3000)
 - Intel Core i3-2330E @ 2.20GHz ([passmark index : 3000](#))
- 2 GB Memory
- 50 GB hard disk. Software requires 20 MB for installation, but storage must be granted for images.

Operating system requirement

- Windows 10, 8, and 7. 32 or 64 bits OS.
May work with windows XP, but no support will be provided for this deprecated OS.

2.2 Camera installation software

Connect the camera to the USB port of your PC where it needs to work with, and the power supply unit. In the **Windows device Manager** form, the camera should appear with an icon tagged exclamation point on a yellow background.

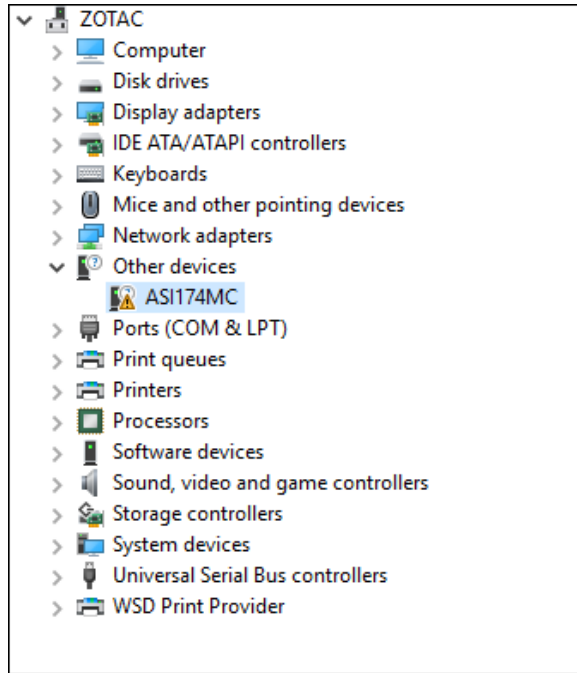

Fig. 26 Lists of Windows' devices (ASlxxxx is the ALL SKY camera)

Run **setup_skywatch.exe**, it will install all the software required for this camera. Be sure that this is **"Skywatch OMEA/ALPHEA Setup"** and not any other setup software (another setup software for EUDA camera is available). The next screen copy shows you how installation runs

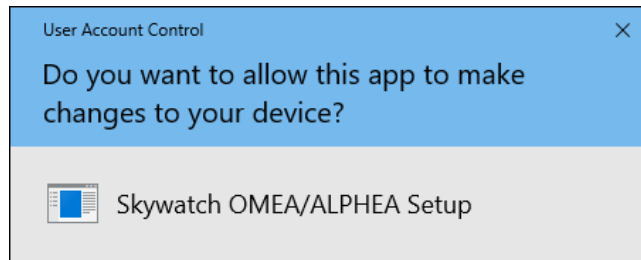

Fig. 27

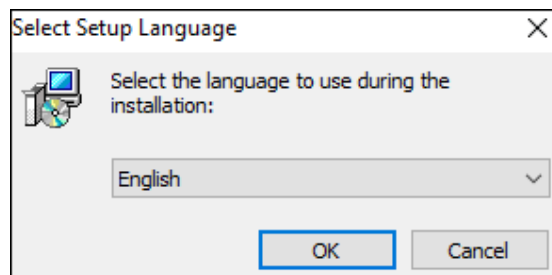

Fig. 28

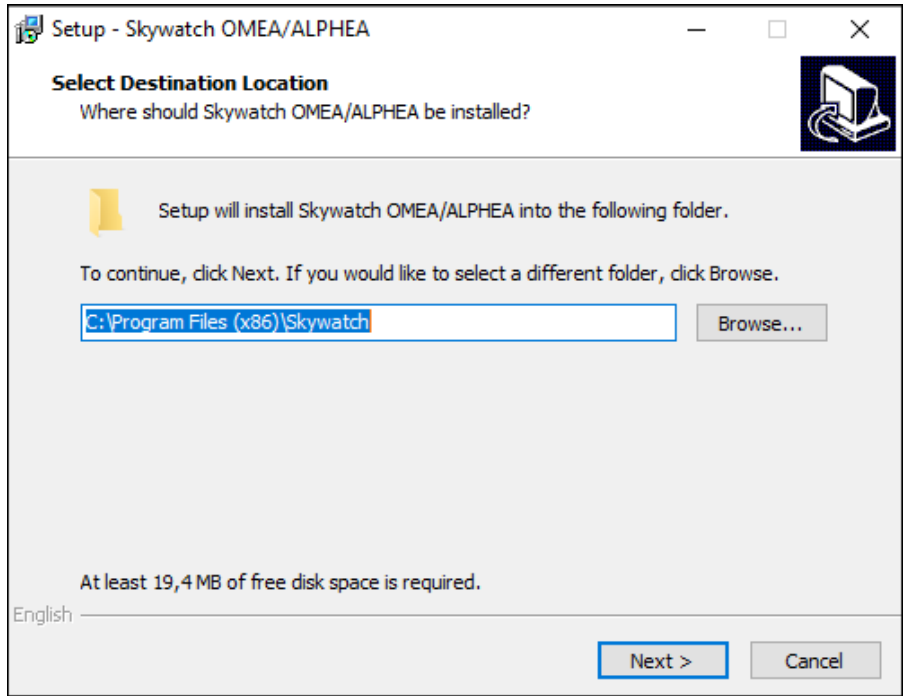

Fig. 29

Then comes the camera driver installation software:

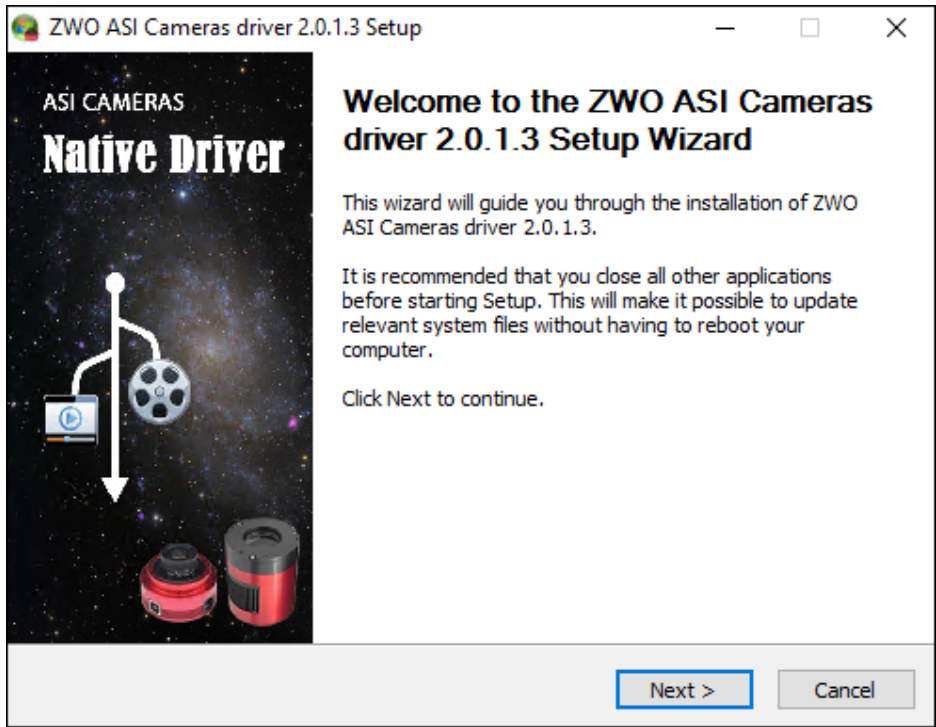

Fig. 30 OMEA Camera device driver installation process.

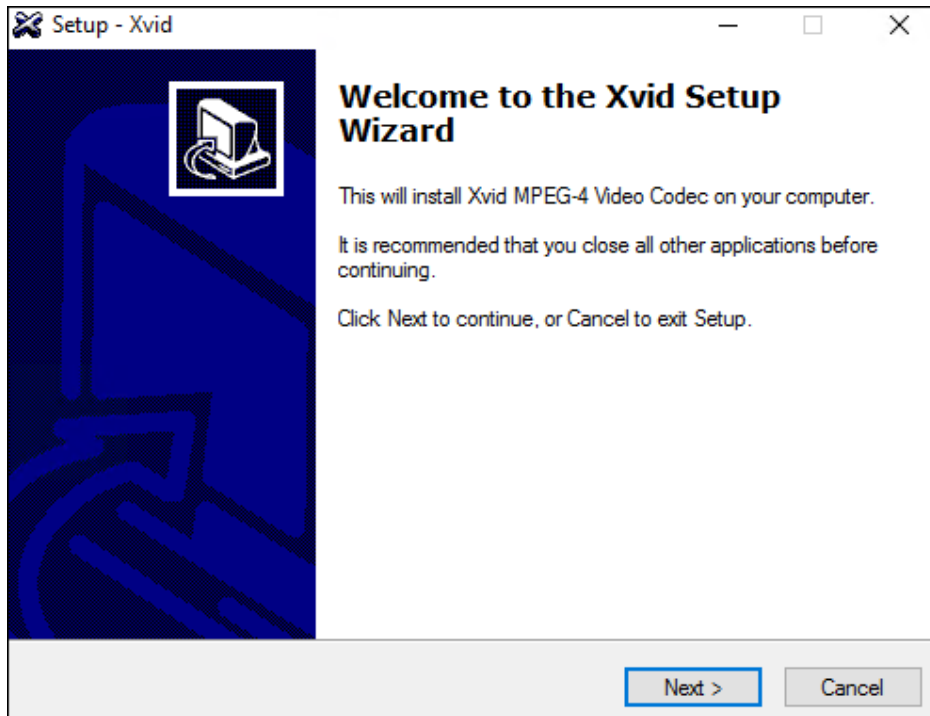

Fig. 31 XVID video compressor installation.

Once the drivers are installed, the camera appears in the device manager either as ZWO ASI178MC, ZWO ASI178MM, ZWO ASI1600-MM Cooled or ZWO ASI1600-MC Cooled, depending on the model of the camera.

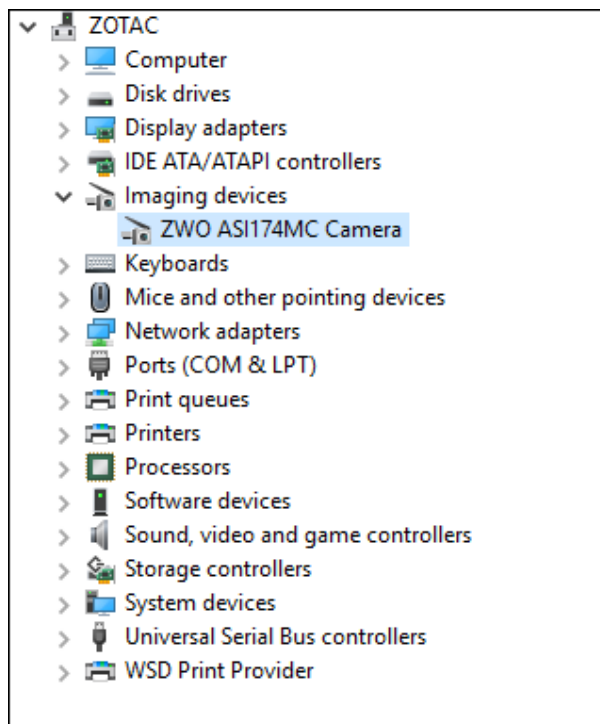

Fig. 32 Camera properly installed in the device manager.

The main's software icon appears on the desktop.



Fig. 33 Icon of the camera software, double click to start it up.

2.3 Embedded Ethernet camera software installation

Warning: basic knowledge of IP LAN setup is required.

An additional step is required for Ethernet cameras, please download software here

<https://www.silextechnology.com/connectivity-solutions/device-connectivity/ds-600>

[Remote USB Device Connectivity over Network - DS-700](#)

This is a USB to Ethernet converter that is embedded into the camera.

This can be DS-600 for camera produced till 2023 and DS-700 for camera produced from 2024. This is the same software.

The “SX-Virtual Link for windows” must be downloaded and installed.

BE SURE THAT FIRST USB DRIVERS OF THE CAMERA ARE INSTALLED prior doing this installation and setup with the ethernet camera. This latter must be connected and powered.

Support

Software:

[USB Device Server Setup](#)
Click on the Software Application to download the latest software file for your product.

SX-Virtual Link Downloads
Click the above link or on one of the options below:

| Software Application | Version | Date | Supported Operating Systems & Notes |
|---|--|---------|--|
| SX-Virtual Link for Windows | 4.4.2 Release Notes | 5/26/20 | <p>Improved the special key control function for Audio and HID devices in Windows 10.</p> <p>Fixed a problem preventing devices from having the ability to disconnect when running specific anti-virus software.</p> <p>Fixed a problem that was causing devices to take a longer time to connect when running specific virtualization software.</p> |

More documentation can be obtained here:

Documentation

[DS-600 Setup Guide](#)

[USB Device Server Configuration Guide](#)

[SX Virtual Link Installation Guide for Windows](#)

[DS-600 Manual for Windows](#)

[Declaration of Conformity](#)

Once installed, the **connect.exe** software (or “SX virtual Link”) must be started.

System (C:) > Program Files > silix technology > SX Virtual Link

| Name | Date modified | Type | Size |
|--------------------|------------------|------------------------|--------|
| Help | 06/03/2014 03:20 | File folder | |
| Setup | 09/03/2014 22:37 | File folder | |
| Themes | 06/03/2014 03:20 | File folder | |
| Win7X64 | 18/05/2016 00:53 | File folder | |
| Win10X64 | 07/11/2016 15:44 | File folder | |
| WinVistaX64 | 06/03/2014 03:20 | File folder | |
| _Setup64.dll | 24/10/2013 16:22 | Application extens... | 53 KB |
| Coflist.ini | 02/03/2020 18:32 | Configuration setti... | 25 KB |
| Connect.exe | 28/02/2019 18:02 | Application | 481 KB |
| Couninst.exe | 14/12/2015 16:40 | Application | 212 KB |

Once “connect.exe” software is started, a panel appears.

The default IP address of the camera (embedded DS-600) is 192.168.1.28 (or something in the 192.168.1.x sub network, X is a figure variable from 2 to 254) or can be set by DHCP server.

The **SX virtual link** software is able to find any device on the network that has the same subnet address as the camera (or embedded DS-600).

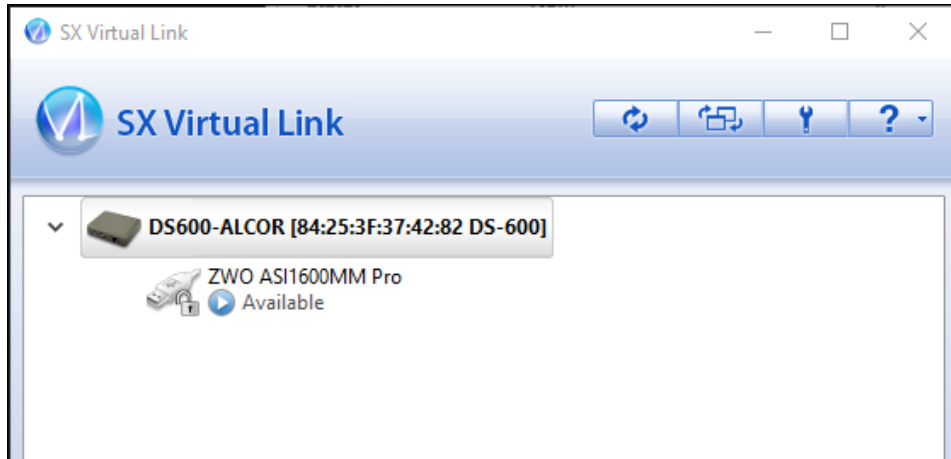

To get the camera connected, right click on the camera and click **“Connect”**

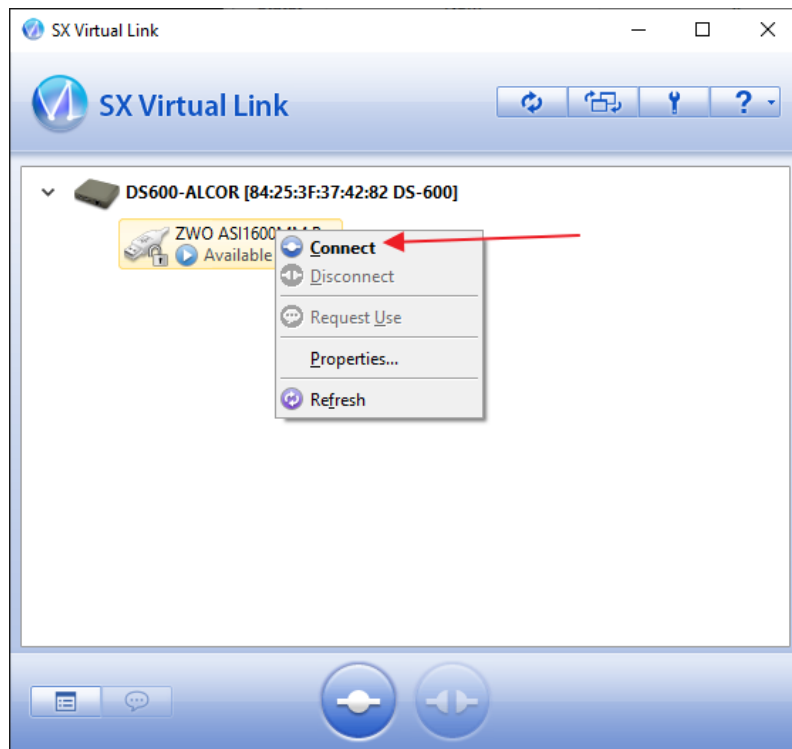

The ALL sky camera is now connected:

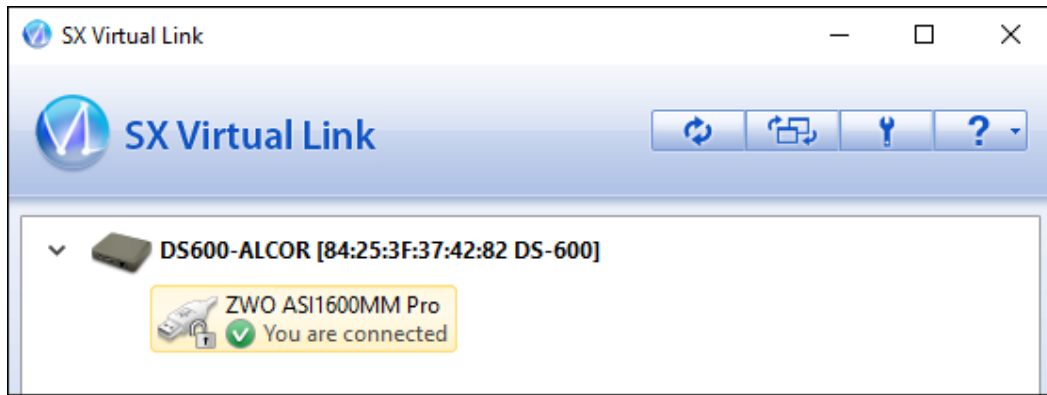

This is possible to auto-connect the camera and the filter wheel, right click on the device, then the pop-up menu shows a property menu. Then go the the “connect” tab.

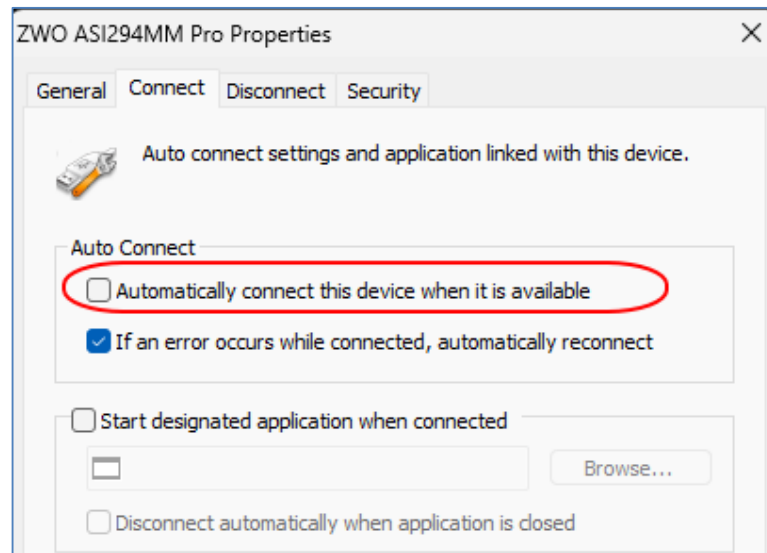

To set/tune the USB to Ethernet device, this link provides access to the configuration panel

<http://192.168.1.28/login.htm?lang=eng>

The password is either to be defined on first access to the web interface or to be provided and is by default “1234” or “root”

■ Welcome to DS-600

Enter the password, and click [Login].

Password

Login

Select Language

English ▼

System status and other information and settings can be accessed and modified.

■ System Status

System Status

▶ System Status

| Name | Status |
|------------------------|---------------------|
| Series Name | silex |
| Product Name | DS-600 |
| Version | 1.4.1 |
| MAC Address | 84:25:3f:94:33:fa |
| Host Name | DS600-9433FA |
| IP Address | 192.168.1.28 |
| Subnet Mask | 255.255.255.0 |
| Default Gateway | 192.168.1.1 |
| DNS Server (Primary) | 192.168.1.1 |
| DNS Server (Secondary) | 8.8.8.8 |
| Current Time | 1970/01/01 09:34:35 |

Note: for Linux user, please go to this page and request for Linux SDK to the USB to ethernet converter company that designed it :

<https://www.silextechnology.com/sx-virtual-link-sdk-linux>

The camera is now visible on the window device manager when connected to DS-600:

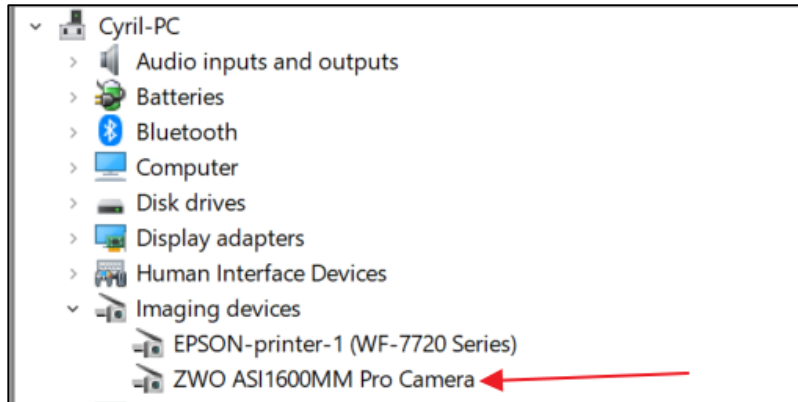



Fig. 34 Camera detected in device manager of Windows 10

More information can be found here:

 [SX Virtual Link Installation Guide for Windows.pdf](#)

 [USB Device Server Configuration Guide.pdf](#)

Or locally here:

C:\Program Files\silex technology\SX Virtual Link\Help

With Silex DS-700, this message might be visible with “USB port error” and a white cross into a red dot. Please ignore the message and the icon this has no impact on camera operation.

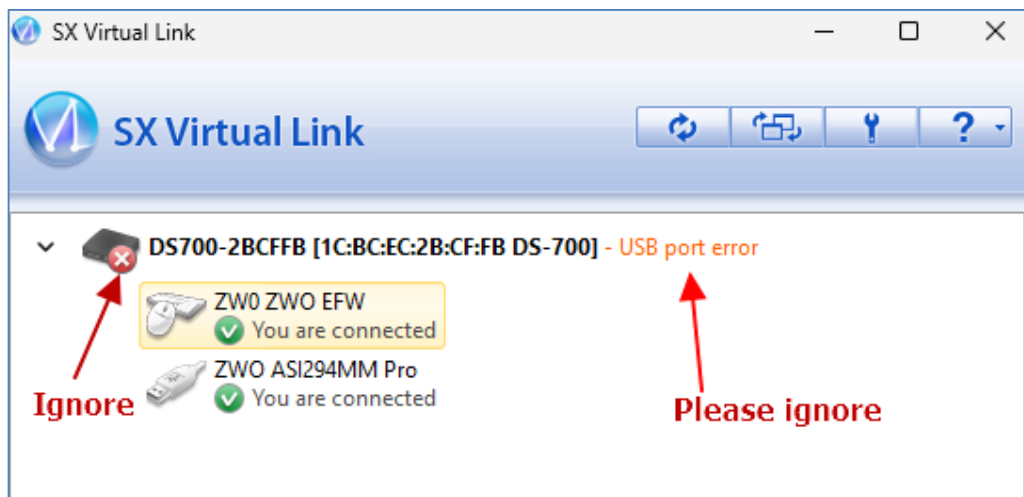

Fig. 35 Silex DS-700 panel (OMEA 5 or OMEA 9 cameras)

To improve the reliability of the data link, the Jumbo packed frame must be enabled, and set to 9014 bytes. Make a desktop shortcut called “*nca.cpl*” to access easily to the network card interfaces (NIC). Go to the **properties** of the NIC, and then click “**configure**” and then go to the advanced tab

In the property, look for “Jumbo Packet” or “Jumbo Frame” and set it to 9014 bytes

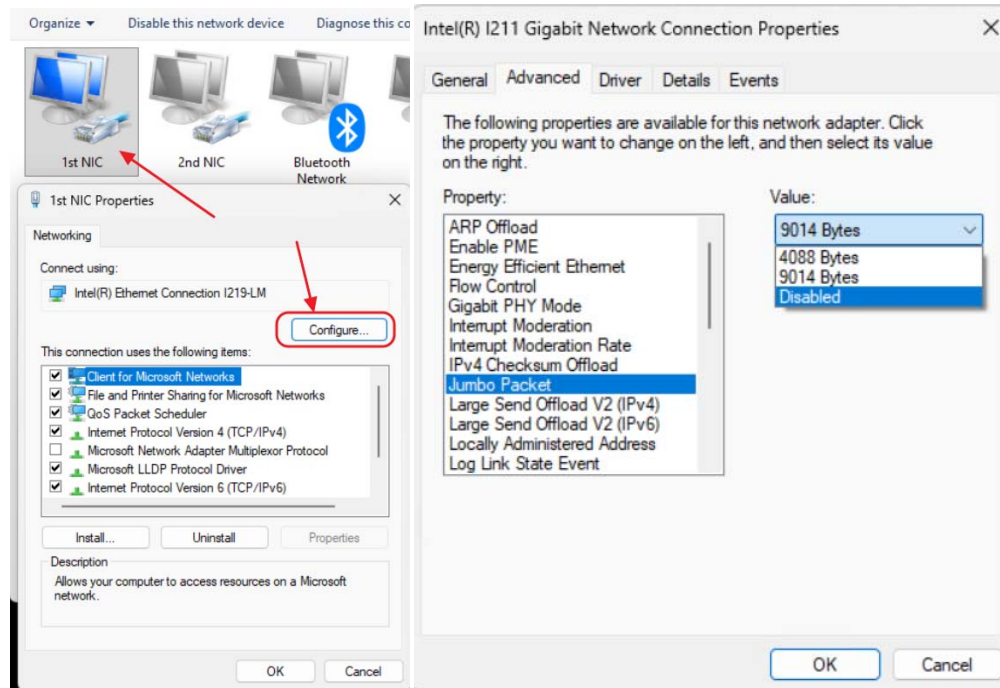

Fig. 36 NIC board setup, set up the Jumbo packet to 914 Bytes

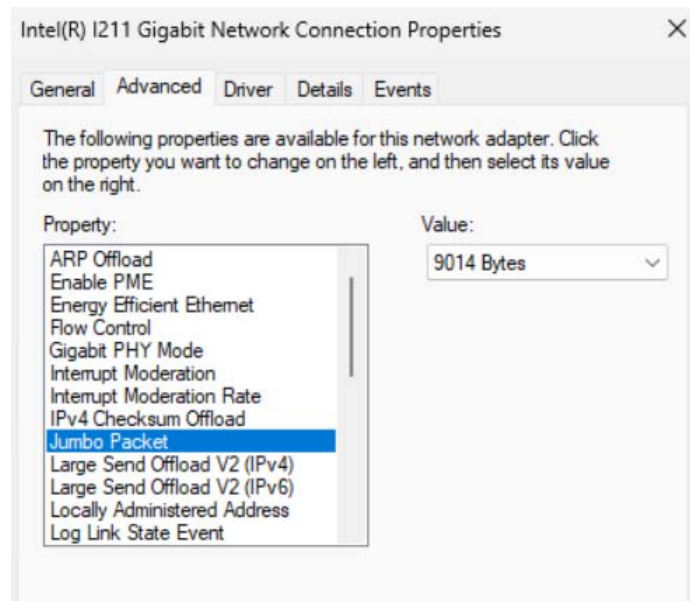

Fig. 37 Jumbo packet is now set to 9014 Bytes

To test that this setting is set properly, open a CMD command window and ping the PC with this command :

```
PS C:\Users\test> ping 192.168.1.12 -l 9014

Pinging 192.168.1.12 with 9014 bytes of data:
Reply from 192.168.1.12: bytes=9014 time=17ms TTL=64
Reply from 192.168.1.12: bytes=9014 time=18ms TTL=64
Reply from 192.168.1.12: bytes=9014 time=10ms TTL=64
```

If the system does not Jumbo Packet it will return a “timeout”

```
PS C:\Users\test> ping 192.168.1.49 -l 9014

Pinging 192.168.1.49 with 9014 bytes of data:
Request timed out.
Request timed out.
```

Despite a regular ping will work:

```
PS C:\Users\test> ping 192.168.1.49

Pinging 192.168.1.49 with 32 bytes of data:
Reply from 192.168.1.49: bytes=32 time<1ms TTL=128
Reply from 192.168.1.49: bytes=32 time<1ms TTL=128
Reply from 192.168.1.49: bytes=32 time<1ms TTL=128
```

- Software installation is now completed -

3 Using the camera software control

This software is fairly intuitive; the documentation will focus on features that are more difficult to acquire. Access to the menu bar is located in the upper left, and a flying window in the foreground can quickly adjust the software settings.

3.1 Initializing

3.1.1 All cameras type

On first software startup, the software display a log window, which disappear by itself within 20sec and heating control window.

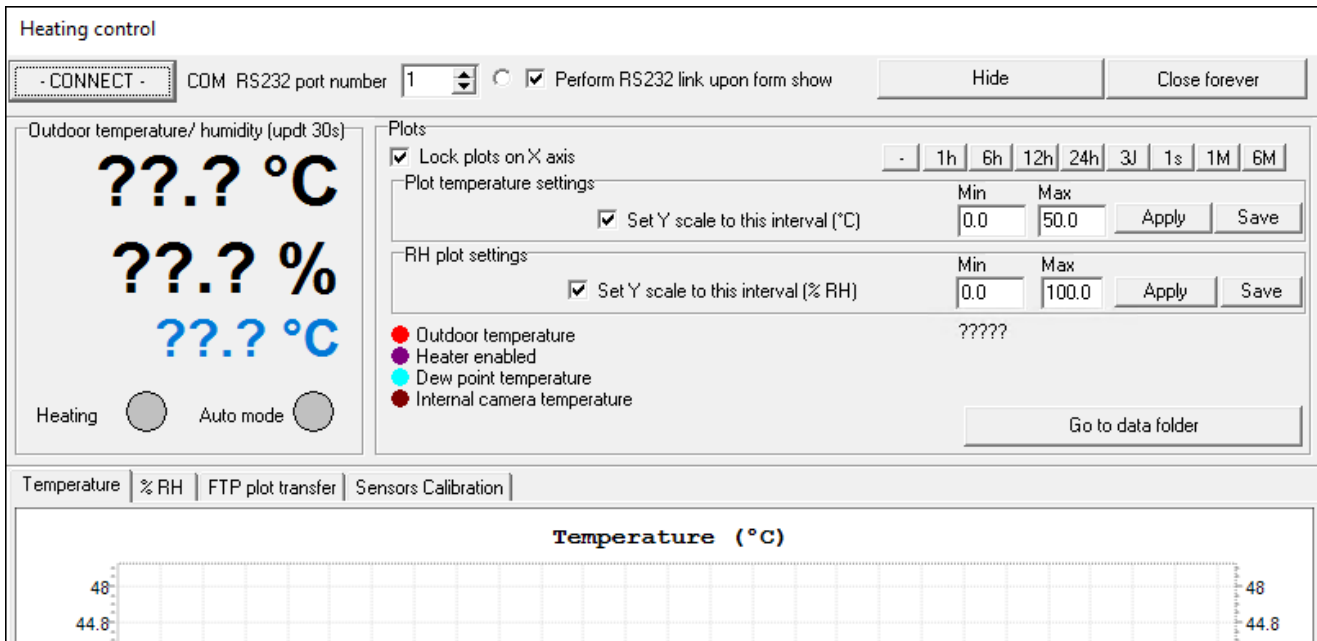

Fig. 38 Heating window software.

Put here the correct COM number, it can retrieved from the “*Device Manager form*”, see §1.3.2

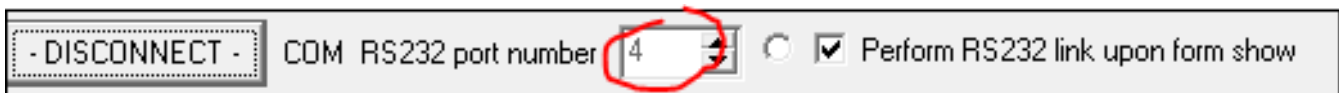

Fig. 39 Port COM setting to connect to the camera, can be any figure from 0 to 255.

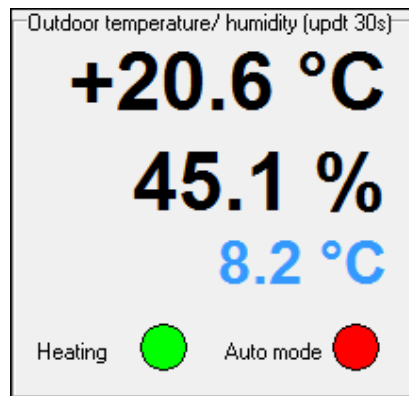

Fig. 40 Once connection is fine, outdoor temperature and relative humidity will display figures instead of “??”.

3.1.2 OMEA 8x/7x/9x specific initialization phases

Once the port COM entered and connected to the camera, for OMEA 8x/7x/9x the user needs to enter the focus encoder value provided by ALCOR-SYSTEM. Say this figure is 1150 (this is for the documentation purpose, not actual value, it may change from camera to camera).

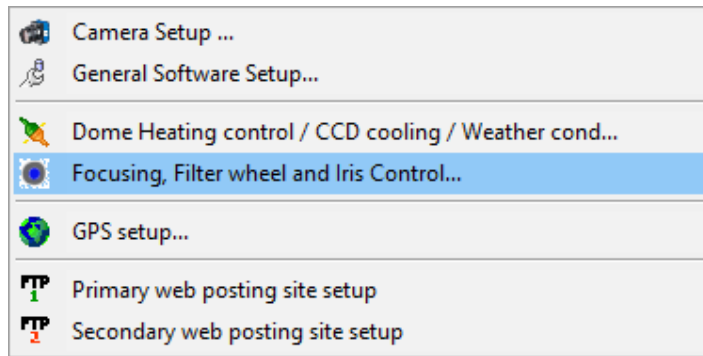

Fig. 41

This form opens, in the **“Focus tab”**, press **“Reference to zero”**, then enter 1150 in the **“Startup reference position”** field, and then go to **“Position to Reach”**, enter the same figure and press **“Apply”**.

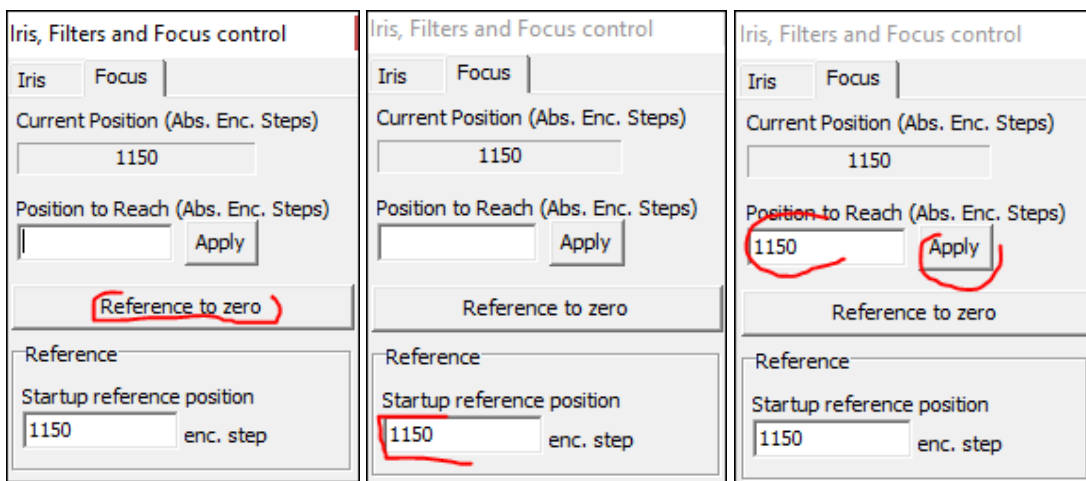

Fig. 42

Focus must be achieved overnight, F2.8 full opened. Zoom must be set to 1. The focus tilt is set on factory, user shall not bother with that. The next set of 6 images shows the effect of different focus encoder value on the image. 1000 is clearly very bad, and 1200 is a good figure (star are sharp), whereas 1400 is not nice. Accuracy must be within +/- 50 encoder steps, difference can be seen between 1150 and 1200 steps. If this procedure is not achieved, images will not be focused properly.

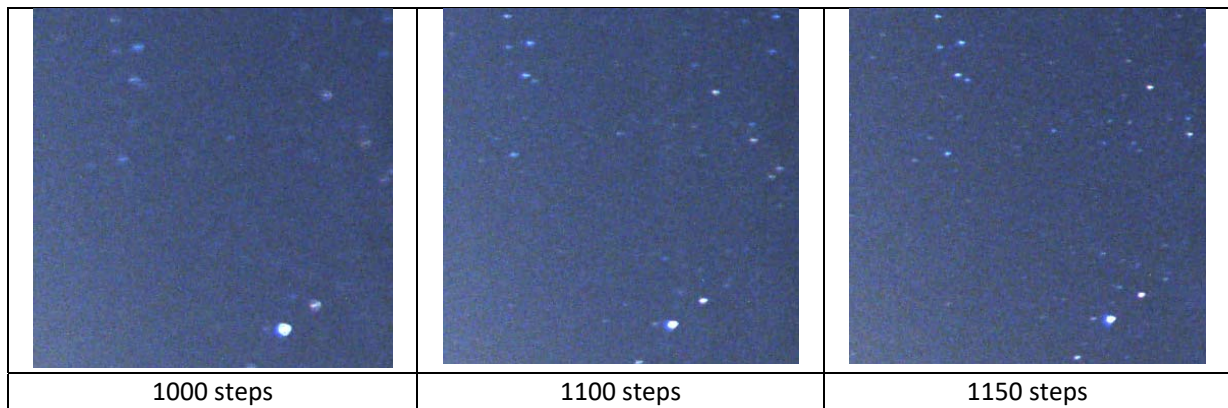

Fig. 43

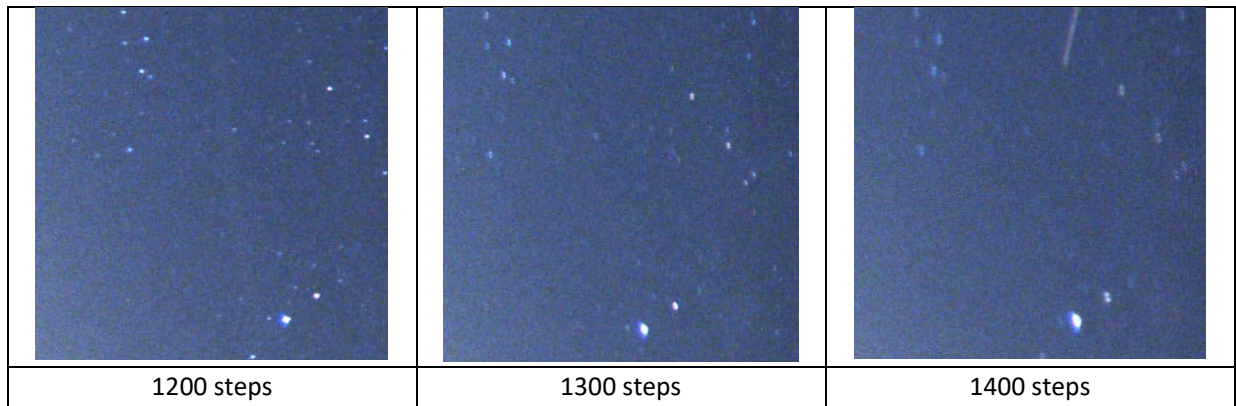

Fig. 44

To save the focuser figure on windows' database registry, do not forget to put it as a reference in the bottom field.

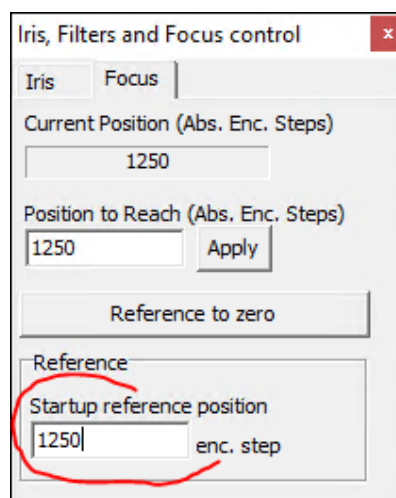

Fig. 45 1250 (that is in this case the best focus) is entered here in order to be saved

F/ ratio can be set in the "Iris" tab for test purposes. It is strongly advised to keep F2.8 for overnight operation of the camera.

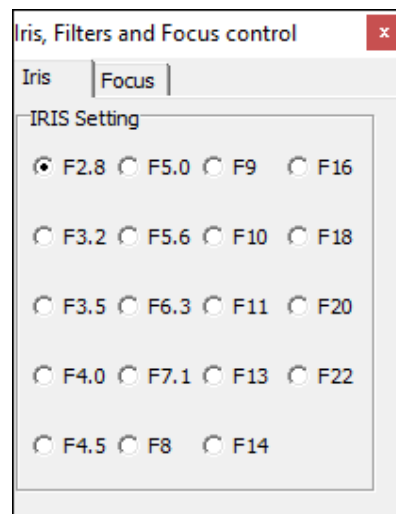

Fig. 46 F/ number control panel

3.1.3 Camera setup

The software is set to simulation camera, and must be changed to the proper camera. Click **“Options/Camera Setup...”**

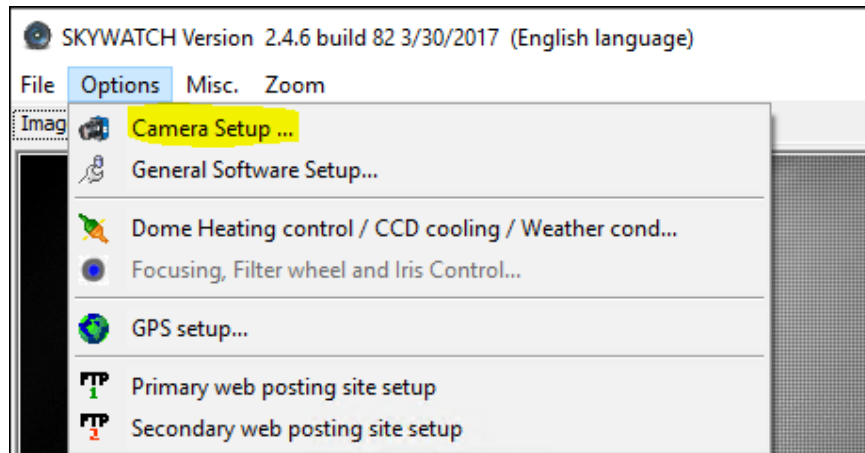

Fig. 47

Select **«OMEA camera....»**, accordingly to your model, the connected camera must appear below:

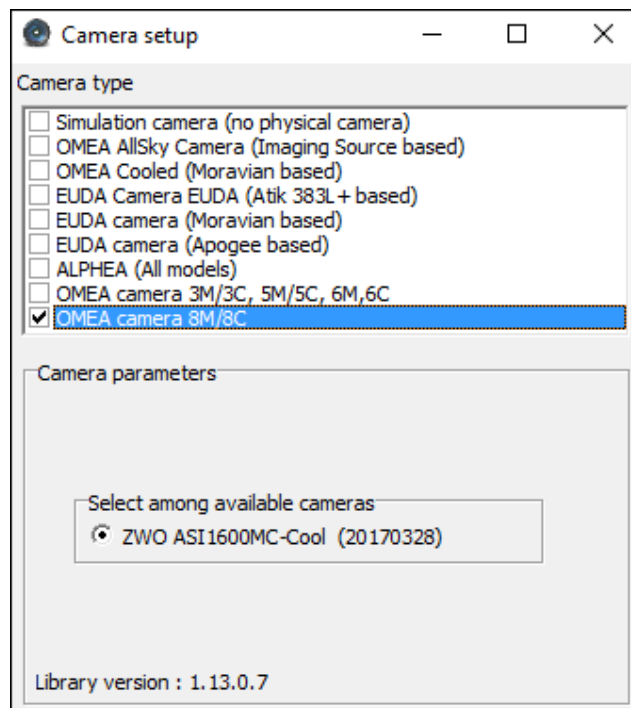

Fig. 48 OMEA 8M/8C has been selected.

When **OK** is pressed, camera will start recording images. Now go to **“Options/General Software Setup...”**

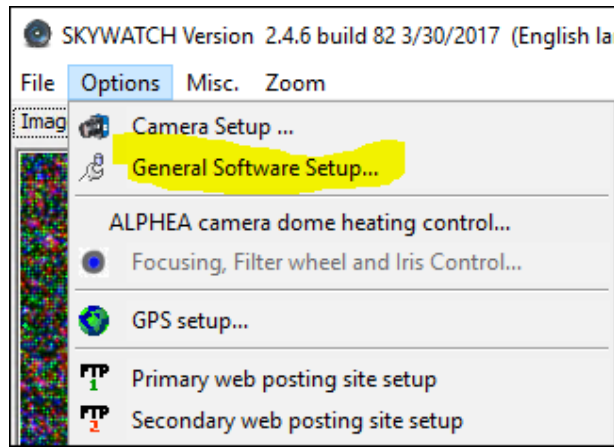

Fig. 49

The next panel appears, and must be filled accordingly, especially this is very important to setup place (longitude and latitude).

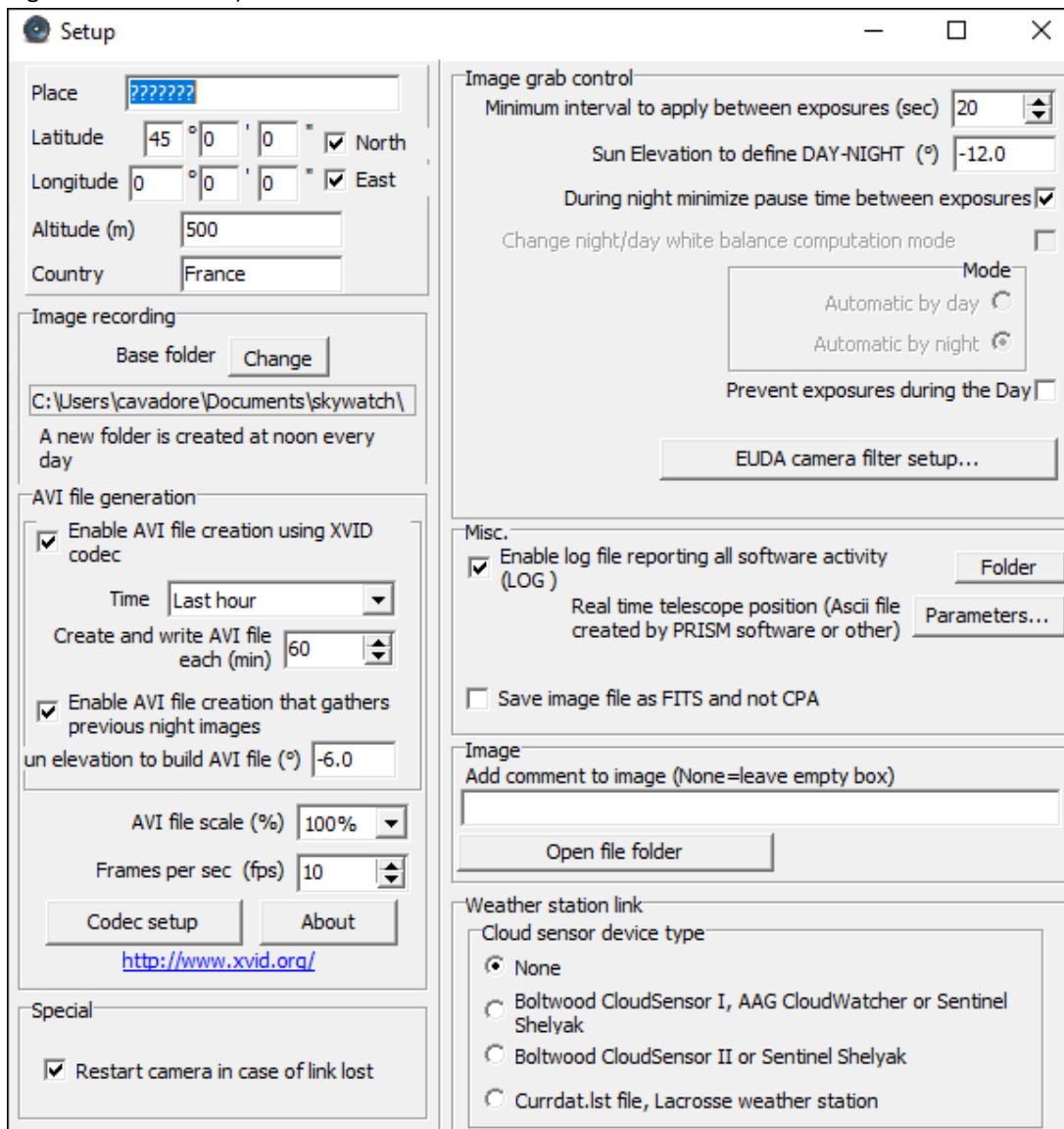

Fig. 50

3.1.4 OMEA 8x/7x/9x cooling setup

OMEA 8x/7x/9x has the ability to cool down the image sensor inside the camera. This only need to be a moderate cooling, because exposure time of the camera is 60s at the maximum. To access cooling control, use this menu:

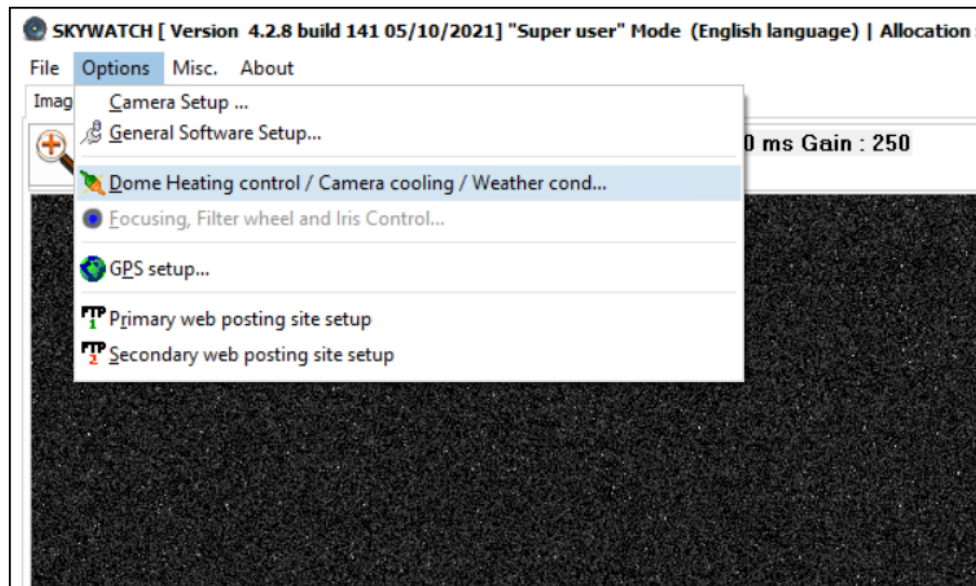

Fig. 51

This form shows up, and the user has to go to the “**Camera cooling**” tab. The hardware link to control the image sensor cooling is the USB link, not the RS232 link.

It is strongly recommended to check the “**Auto cooling**” box, which will disable cooling during daytime and enable it during nighttime.

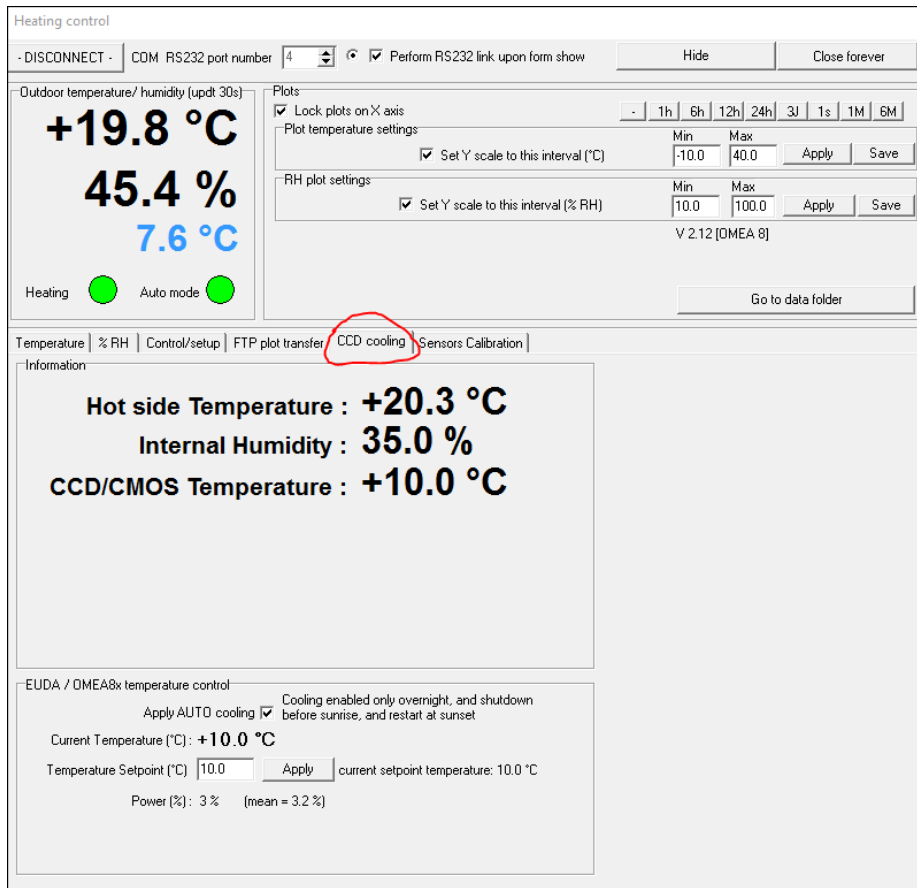

Fig. 52

It is recommended to set temperature set point to 0°C in summer, and -10°C in winter. In any case, the system will raise automatically sensor temperature if power used is larger than 60%. Also on software exit, the camera cooling is turned off. Image sensor temperature is plotted in the temperature tab plot.

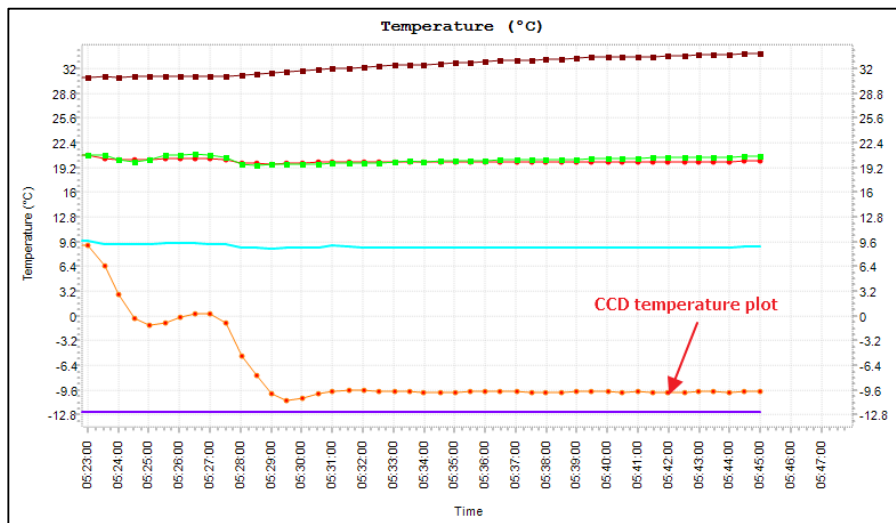

Fig. 53

3.1.5 Exposure control

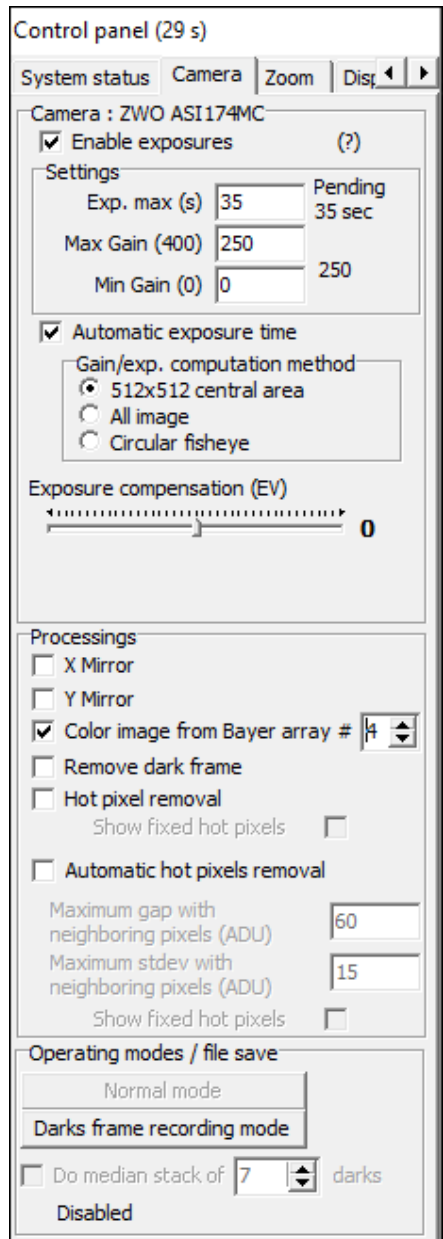

Fig. 54

Once the camera is selected, the exposures start immediately. Then, do not forget to check the "**Auto Exposure**" box after the first image has been displayed. It should be by default.

For color camera, the raw image from color camera is a black and white, this is called Bayer pattern image. So the true color image shall be computed.

Check the box "**Color image from Bayer array**" and set it to **#4** for OMEA 3C/5C/6C cameras and to number **#3** for OMEA 8/9/7C.

Only the color cameras have this option enabled, monochrome (black and white camera) does not.

Maximum recommended gain is 250 for OMEA 3C/6C, the more the gain is high, and image quality will be jeopardized by image sensor readout noise.

Going above these settings may jeopardize image quality due to high noise.

Maximum recommended exposure is 30s OMEA 8x/7x/9x and 45s OMEA 3/6xx. Going above these exposures times may render visible star trailing due to Earth rotation.

Then check "**Circular fisheye**" for the area to be used for computing automatic exposure time.

The area used for auto exposure computation, is displayed in red in the image of the sky.

It is very important to tune this circle properly, then go to the **Display** tab in the control panel form.

They check boxes as follows, and tune the X center, Y center, Radius, and north position, so that the stars match with the cross.

To be successful with this operation, the camera must **be positioned with a water bubble level**. If the camera is tilted, the matching between the star cross and the actual star in the image is not possible.

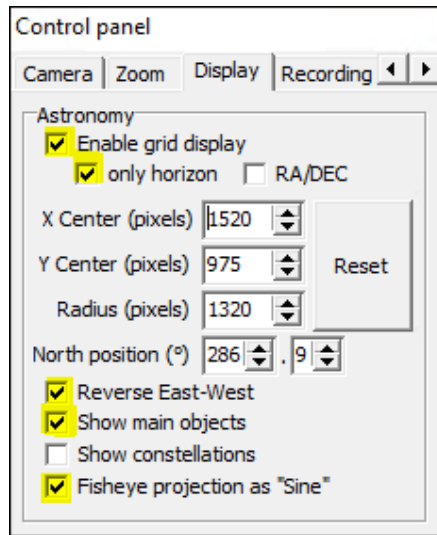

Fig. 55 Defaults settings for ALPHEA cameras

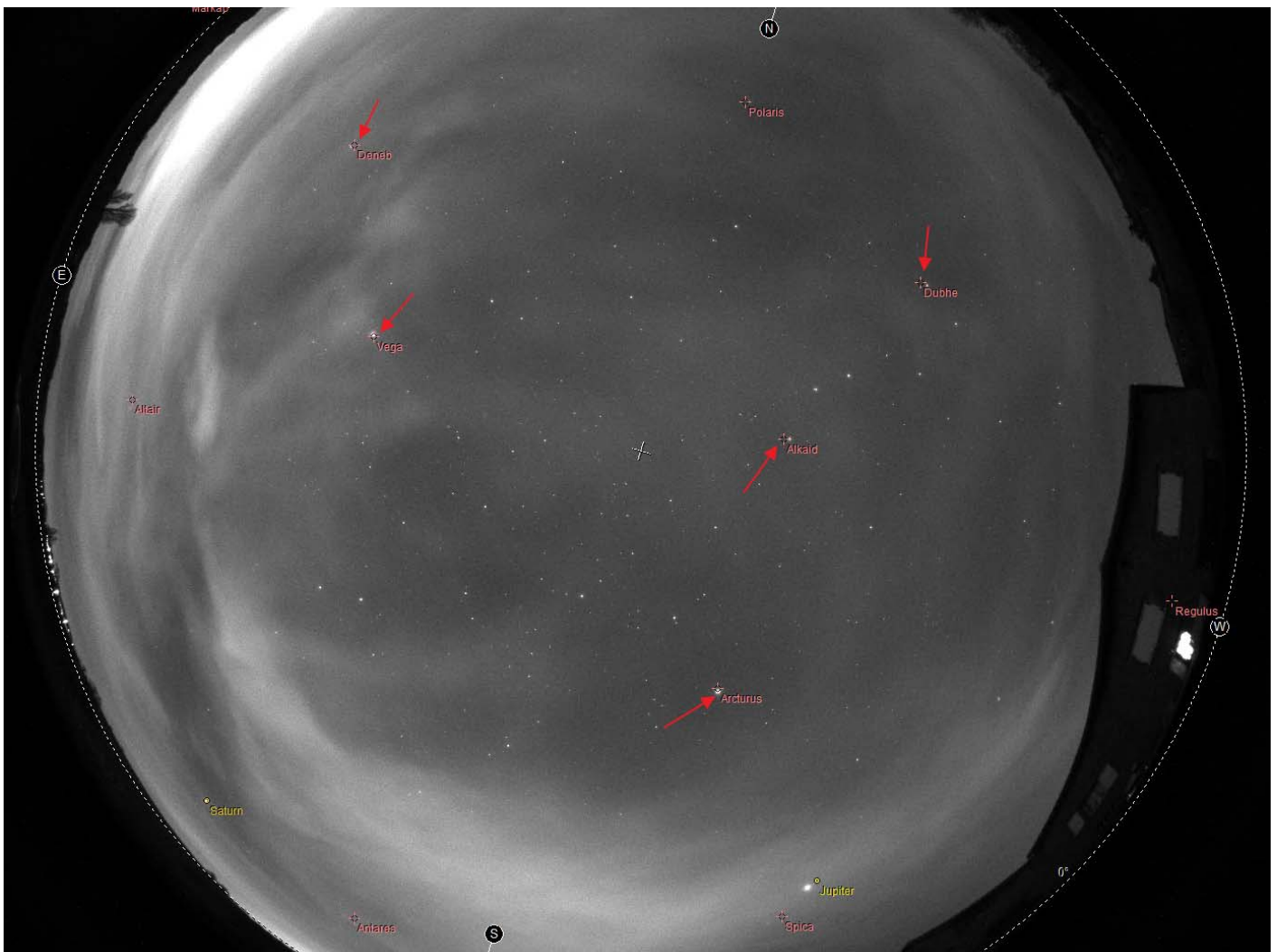

Fig. 56 Setting of the field circle that represents horizon, and cross for stars

3.2 Storage of files produced by the camera control software

The software stores all the files it produces into a directory that is specific to the user.

This directory (and subdirectories) is created automatically by the software. It is set by default, as shown in the next image, i.e This **PC > Documents > Skywatch**, that translates into **C:\Users\[Login name]\Documents\skywatch**, where [login name] is the name used to log into your windows session.

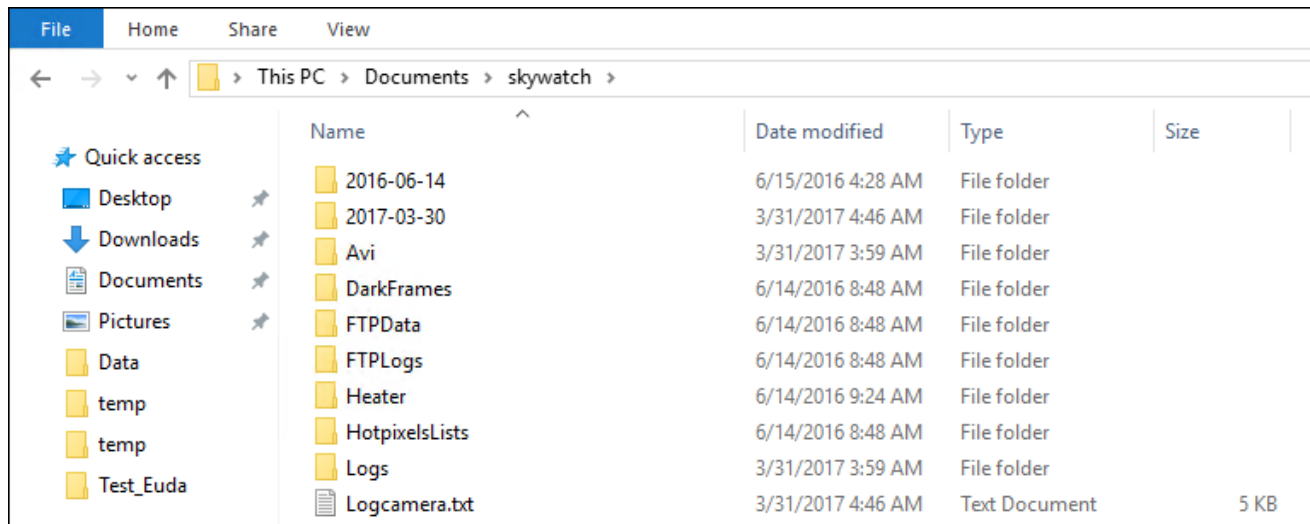

Fig. 57

- The subdirectory **AVI**: contains the latest videos generated by the camera control software.
- The subdirectory **DarkFrames**: contains the images needed for camera hot pixels removal. All CPA files found there are tried by the software to find the best dark frame to be used to remove camera hot pixels.
- The subdirectory **FTPData**: contains the final JPEG image produced to be uploaded on user's website
- The subdirectory **FTPLog**: contains the log files generated for each image transfer to the website. These logs help to find out issues when transferring files to user's website.
- The subdirectory **HotpixelsList**: contains the *hotpixlist.cos* file used to make hot pixel corrections that were not removed by the subtraction of the optimized dark master frame. *Hotpixlist.cos* this is an ASCII file where each line describes the correction to be made to a given X/Y pixel

For instance:

```
fill 103 360 1
fill 289 570 1
fill 304 125 1
fill 664 326 1
```

The first line indicates that the pixel located at X = 103 and Y = 12 and a single pixel size shall be corrected by its neighbors pixels.

This correction takes into account that the image is a Bayer pattern array (color camera) and picks up neighbors pixels accordingly.

This file can be automatically generated from a feature from this software (see next paragraph)

- The **Logs** files subdirectory: contains the log files of the software, in which are written the software actions and events as a text file. This is for debugging purposes. A new file is created each time you start up the camera control software.

The log file is enabled into the main's software setup panel.

- The subdirectory **Year_month_Day like 2016-06-14**: contains image files that are saved automatically by the software as jpegs files or CPA/FITS files.

The directory is used from noon to noon. For instance images created from 12:00 on May 10th 2010 till May 11th, 2010 at 11:59 will all be stored inside 2010_05_10 subdirectory.

3.3 Camera exposure time and gain

The software has two recording modes:

3.3.1 Manual mode

The user enters the exposure time and gain as he wishes. No adjustment is made by the software.

3.3.2 Automatic mode

The software manages the exposure time with focusing on the camera gain. It is up to the user to set the maximum gain and maximum exposure time he wants to use. The software can use a calculation area of 512x512 pixels at the center of the whole image, all the image or circular fisheye, with the aim to adjust the gain / exposure time to get a signal level located at half the camera dynamic range. When the settings are changed, regarding which area will be used, a red shape appear on the image during some minutes as a reminder of the selected area.

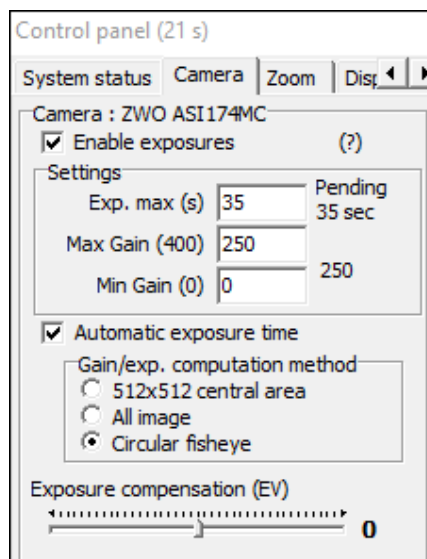

Fig. 58

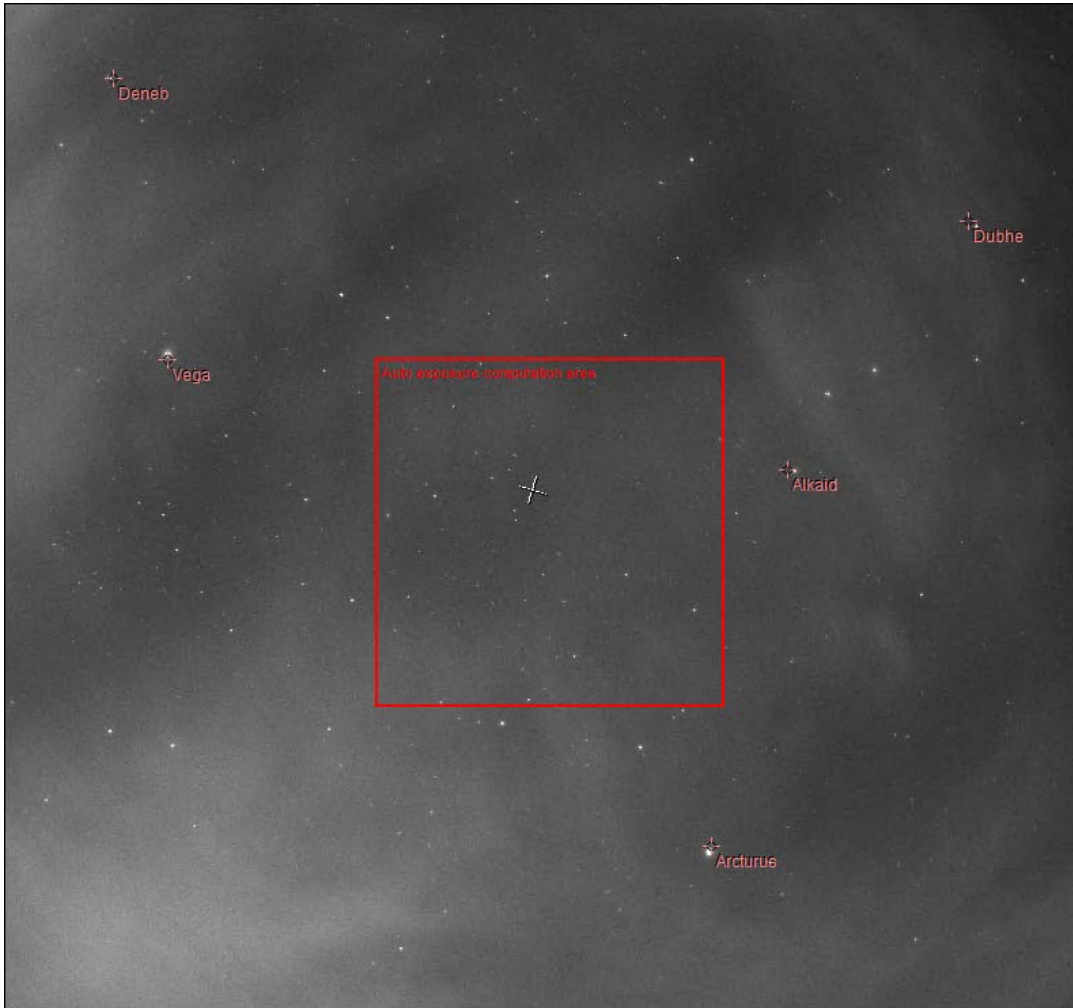

Fig. 59 If the computing area for auto exposure is set to 512x512 image center, this shape is drawn to show where the bounds of this area are located.

When determining the maximum exposure time, the user shall bear in mind that the minimum exposure time is $32\mu\text{s}$ (0.000032 sec) and the maximum exposure time will depend on when the stars will start to leave traces due to earth rotation.

3.4 Image hot pixel removal using dark frame image

**For cooled cameras such as OMEA 5x and OMEA8x/7x/9x, this chapter can be ignored.
For other cameras, this can also be ignored in most cases (high latitude sites, with cool nights)**

The camera embedded in this system is not cooled sensor camera, but hot pixels can be removed thanks to software features.

Dark frame removal is important to get rid of hot pixels and is fundamental to get good image quality.

The raw image from the camera must be completely corrected for thermal effects of the camera. These thermal effects result in the presence of hot pixels (as bright / colored pixels). In the case of color camera these hot pixels turn into colored dot with showing pure color (blue, red or green) that affect strongly image

quality.

Production of hot pixels depends mainly on the temperature of the image sensor camera that is bound to external temperature. More the camera is being used under conditions of high temperatures, more the number of hot pixels. Exposure time also affects strongly the number of hot pixels: the higher the exposure time, the higher the number of hot pixels.

The following series of images is quite demonstrative: in case of a black and white camera, the pixels are white hot and occupy a single pixel. It is possible to confuse them with stars, but their existence in areas without light reflects an important problem of image quality.

In the case of a color camera, the effects of hot pixels are even worse: they are strongly colored (red or green or blue), and the eye can detect them very quickly. The image quality is highly degraded, the image is filled with colorful hot pixels altering image rendition.

It is therefore essential to correct these hot pixels using an "dark" master frame, and possibly complete the task with a list of pixels to fix.

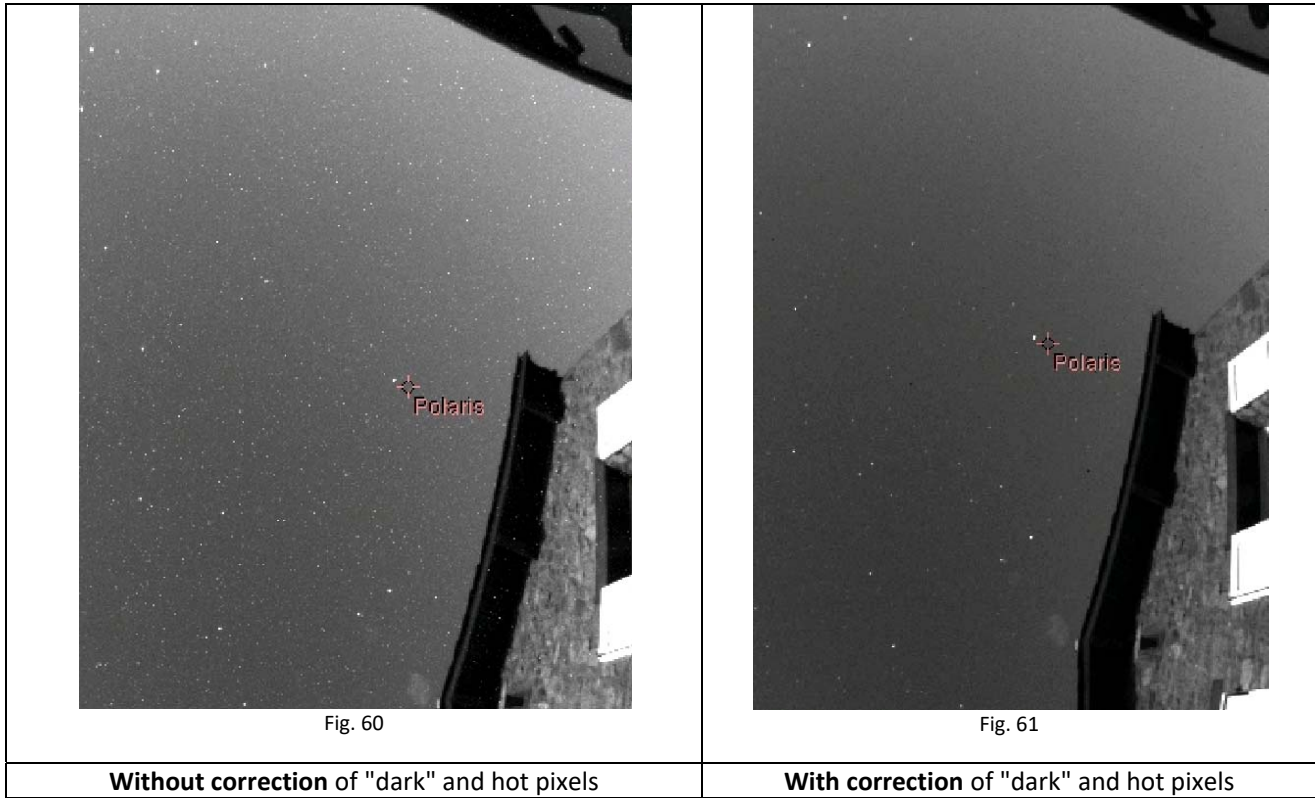

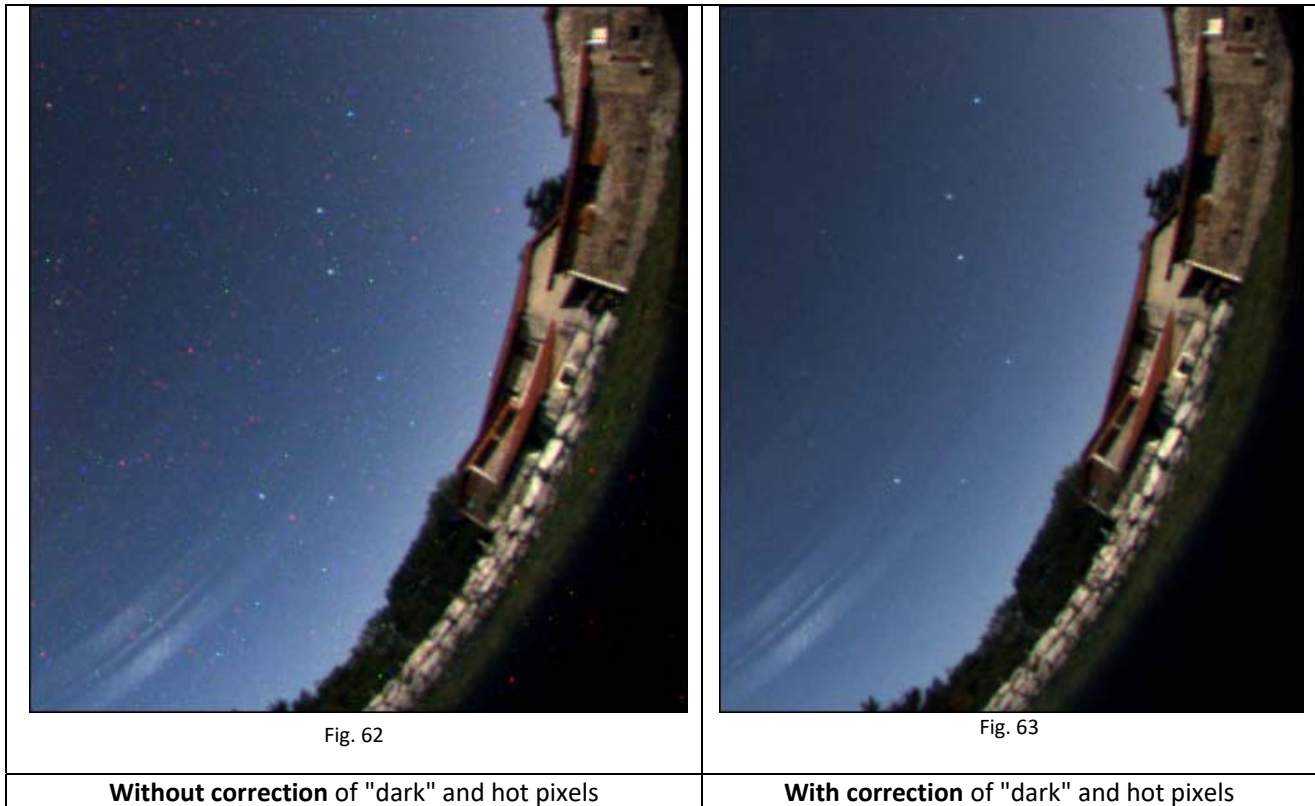

The software performs hot pixels fixing in three ways:

- By subtracting a master dark frame.
- Local pixel correction from a list of hot pixels
- Automatic local hot pixel removal based on two parameters

Activation of these corrections is achieved using the main camera control panel, camera tab, then on the following checkboxes **"Remove dark frame"**, **"Hot pixel removal"** based on pixel list coordinates or / and **"Automatic hot pixel removal"**

The master dark frame is located in this folder:

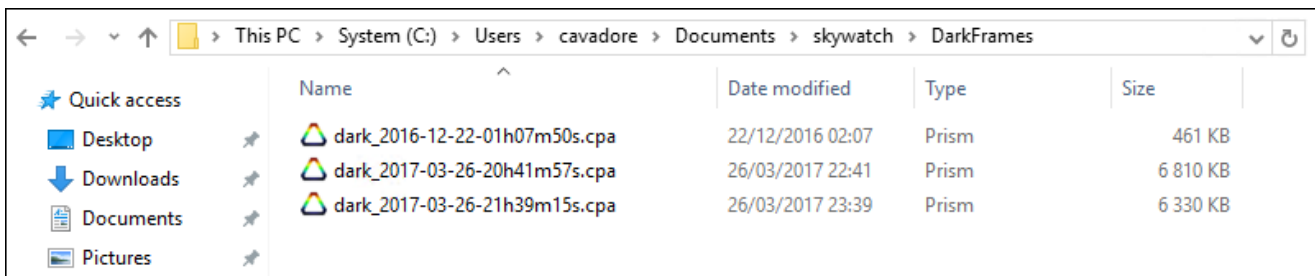

Fig. 64

During day, the dark frame correction is not performed, because negligible, as exposure times of approximately 1ms to 32 μ s avoids hot pixels presence. This is not the case at night when the exposure time is 600 000-750 000 times higher than during day.

If no dark file cannot be found inside this "Dark Frames" folder, if the image file does not have the same size in width or height, or if not the same pixels type, a message error will be displayed in the status tab of the control panel.

This dark frame subtraction is performed through an optimization algorithm of the coefficient to be applied to the master dark frame image. If many files are present, the software will select the master dark frame that provides a result that is closest to 1.0.

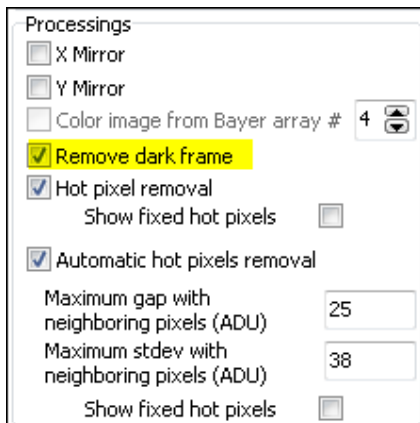

Fig. 65

The software scans the presence of files in the *DarkFrames* folder and will automatically pick up the most appropriate.

This means that if the master dark frame was produced at a given temperature, a given exposure time and a given gain, the software is able to optimize the subtraction of the current image by the best dark frame, even if there were temperature changes. This is performed within a reasonable range of variation. It will be discussed later on the effects and validity of the dark master frame according to the variation of parameters.

As there are still hot pixels that have non-linear behavior and cannot be corrected by the dark master frame, correction using hot pixels list can be achieved, cleaning the image of hot pixels by its neighbors. Just check the box highlighted in the screenshot below.

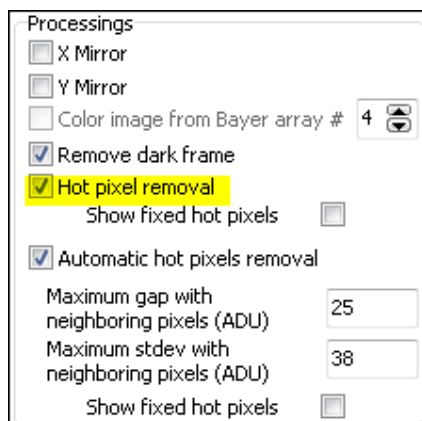

Fig. 66

The file used for this operation can be found here:

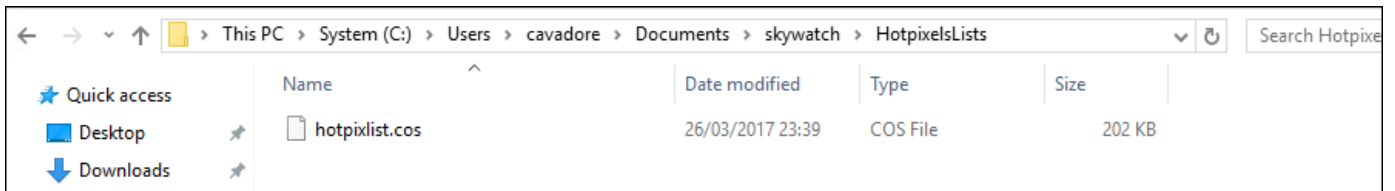

Fig. 67

It contains a list of hot pixels to repair/fix.

3.4.1 Achieving master dark frame

The files located into DarkFrames folder, whose fundamental purpose has been presented above, may, in some cases no longer be adapted to the current image shooting conditions (due to seasonal temperature changes). This is especially the temperature change that will determine the validity of the master "dark" frame. This validity is above/below 5°C the temperature where the master dark frame has been recorded. Beyond this temperature range, the image hot pixel repair/removal using this dark frame might become poor and not effective.

For example, a master "dark" frame recorded from a set of some dark images at 20 ° C will be valid for images acquired between +15 °C to +25 °C.

It is better to build a small library of "dark master" for each 5°C (outdoor temperature)
The software will automatically select the most appropriate in the "DarkFrames" folder.

How to make a master "dark" frame for a given outdoor temperature?

This is easy. Under "**Camera**" tab, uncheck "**Auto Exposure time**" and select an exposure time corresponding to the longest exposure time used during night, for example 30s

Concerning gain, the largest gain used during night, for instance 150 (and then "**Apply**")

Operate during night ONLY and cover the system (the Plexiglas dome) with a black tissue, or black paper. Be sure that any stray light cannot penetrate to the camera lens. Warning, it's a fisheye that is mounted on the top of the camera, and it able to see 360 ° down to the horizon

A feature has been implemented to achieve a master dark frame, and also can compute a list of hot pixels too.

Press the "**Dark frame recording mode**" and check "**Do median stack of**" say 5 to 11 "**darks**".

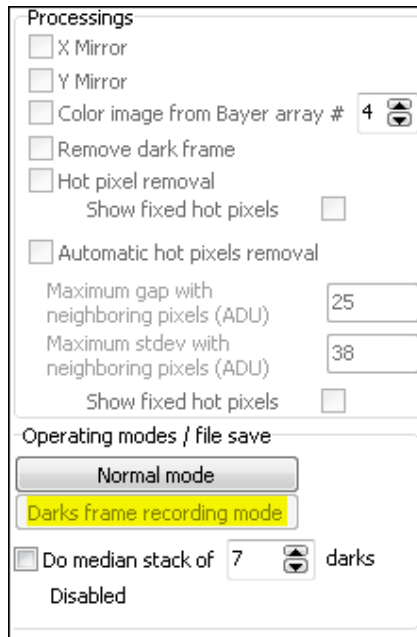

Fig. 68

The software switches into a particular mode that allows it to produce "dark" frames and performs the median stack when the number of required dark frames have been reached in order to achieve a dark master frame and a list of hot pixels.

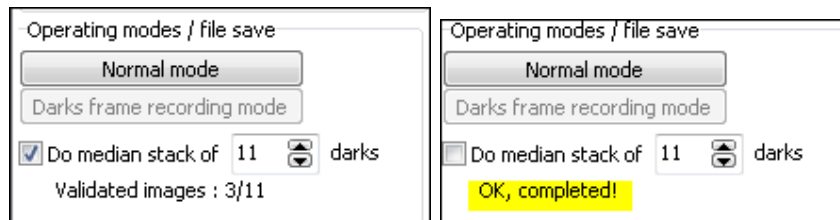

Fig. 69

The resulting files are placed in the proper directories **and are immediately ready for use.**

Once the task is complete, click on **"Normal mode"**

Enable the following features by checking the following boxes:

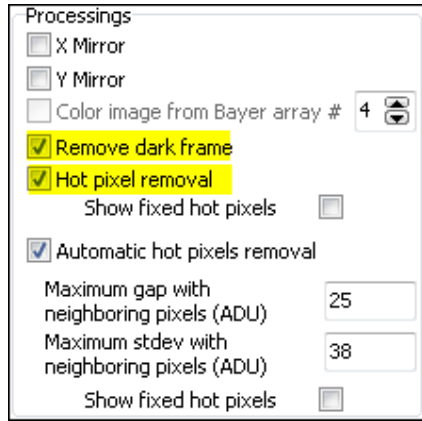

Fig. 70

For each image recorded by the camera, the dark master frame file will be used in the form:

$$\text{Displayed_image} = \text{Raw_Image} - (k * \text{Master_dark_frame_Image})$$

Where k is a coefficient optimized by the software.

More k is close to 1, the better. In the following scenario, k = 0.95, which is a good value.

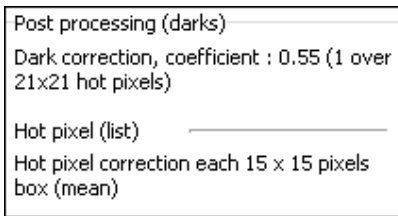

Fig. 71

If $k > 1.5$ or $k < 0.5$, it means that the master dark frame is not well appropriate to the current outdoor temperature conditions. A warning message will be displayed as a red sentence.

3.4.2 Residual hot pixels repair/fix

For cooled cameras such as OMEA 5x and OMEA8x, this chapter can be ignored.

For other cameras, this can also be ignored in most cases (high latitude sites, with cool nights)

Despite the subtraction by a master dark frame, and the repair of hot pixels based on a list of coordinates, some hot pixels are still variable (appear and disappear from one frame to another). To remove these last hot pixels that can't be removed previously, the next checkbox shall be enabled:

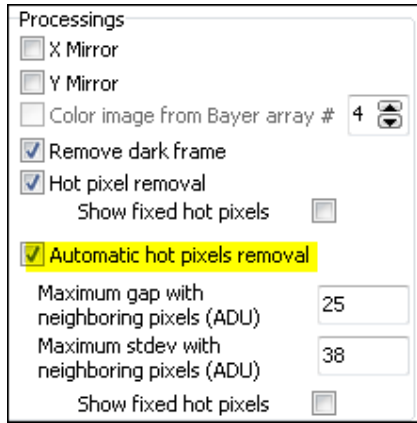

Fig. 72

The algorithm automatically eliminates hot pixels by inspecting all pixels from the incoming image. Two parameters to set two conditions are necessary.

The first parameter defines the difference of the pixel compared to its eight neighbors for which that pixel will be considered as potential hot pixels because it exceeds the defined gap (as ADU).

The second parameter sets the maximum standard deviation of the eight neighboring pixels, if the deviation is less than the defined value; the central pixel is considered as potential hot pixel.

When the two above conditions are met, the hot pixel is fixed automatically.

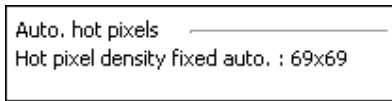

Fig. 73

The figure above shows that the automatic correction is performed on average into one pixel every 69x69 pixel box. To test this feature, use a moonless night, and be careful not to remove some stars of the picture by setting a too low maximum gap and too high standard deviation!

You can see how these fixed pixels are spread over the image, by enabling the following checkbox.

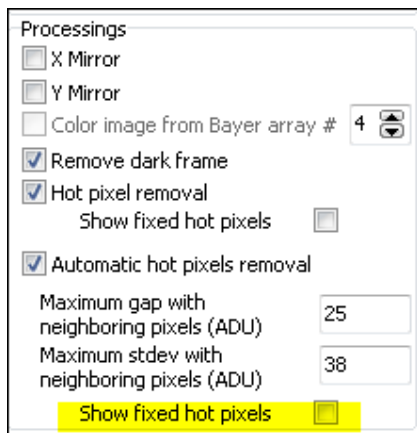

Fig. 74

A pixel density corrected that implies one pixel every 7x7 pixels box is maximum, beyond this density, such as one pixel each 5x5 pixel, you will have to achieve your "dark" frame and the list of hot pixels bound to it.

3.5. Embedded Image Status information

In JPEG image, a cartridge is indicating camera statuses, "2129" indicates the number of images taken since the software has been started up. "D 1.6" indicates a correction by a factor 1.6 of the dark frame; "H" indicates hot pixel correction using a list, for example "18x18 H" indicates that an average of one pixel of 18x18 pixel bow is repaired. If H! is displayed, this means that the hot pixel file was not found. The "L 9x9" indicates an automatic correction of hot pixels having an average density of 1 pixel per 9 by 9 pixels.

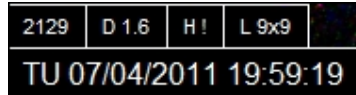

Fig. 75

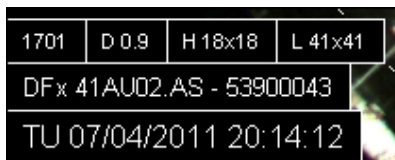

Fig. 76

3.5 Setting the overlay grid

The camera must be installed vertically using a water "bubble" level. Otherwise, the setting of this grid will be impossible.

Here is the recommended way to set the grid that is used to identify stars on the image: this is not an automatic procedure; this setting shall be performed manually. But once set, this will be set forever (except the camera is being moved or rotated). In the Control Panel, set the location, latitude and longitude, altitude, and the country.

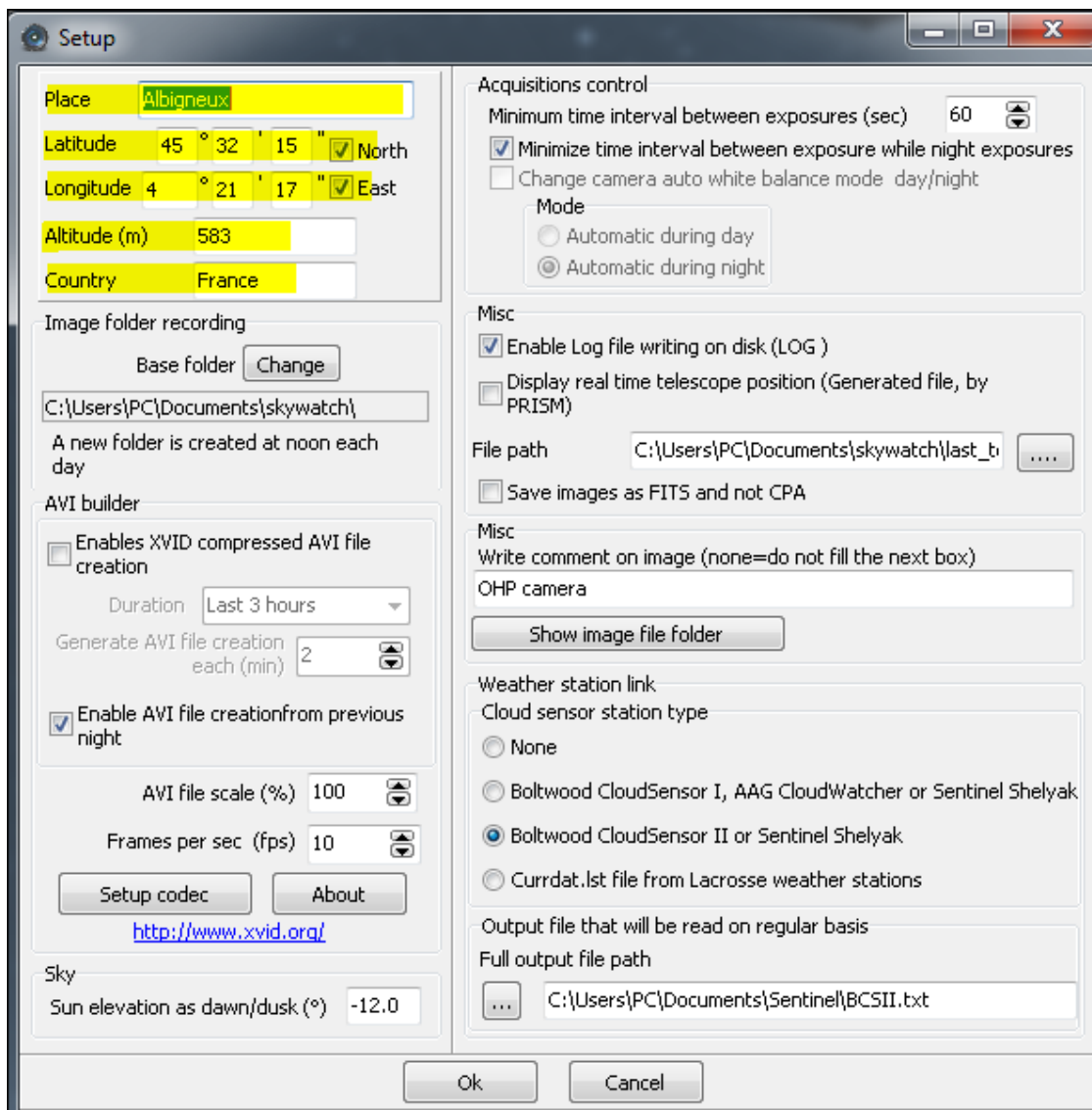

Fig. 77

- Use night time when a star of magnitude 0 to 3 passes to zenith (or say +/- 2° from the zenith)
- Force fixed exposure time of 5s to 10s
- Get to "**Enable grid display**" and "**Show Main object**" (Check "**Only horizon**")
- Find the star that passes nearby zenith and move the cross indicating zenith towards it.
- Change "**X center**" and "**Y center**" figures so that the cross position matches with the star.

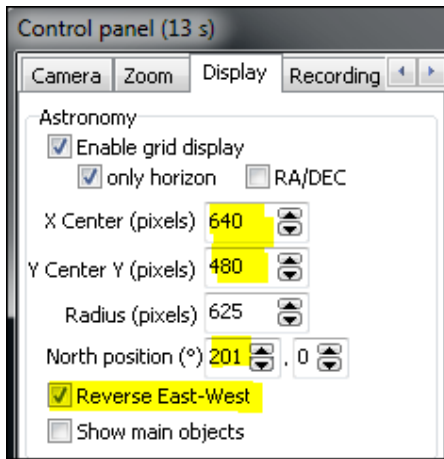

Fig. 78 displacement in X and Y to adjust the position of the zenith symbol



Fig. 79 Star passing nearby zenith (Deneb) and zenith marker

- Once the zenith marker found, you have to set the "north position" to have the grid (circle and star's name) matching with star position. The grid scale can be changed also. The grid (or set of stars position) is changing according to the time and geographical coordinates. Be sure to have set these parameters correctly.

3.6 Cyanogen Boldwood or Sentinel cloud sensors link with camera control software

If you own a cloud monitor from Cyanogen or Shelyak companies, it is possible to display, at the top right of the image, some weather information. In the main Setup Panel, enter appropriate information. The software uses simply the output file generated by each measurement from cloud sensor. It does not use the COM or ActiveX interface. Enter the path of the generated file provided by the software that runs the cloud sensor.

The amount of information depends on the system that is measuring cloud cover. It will be the most complete using Sentinel Shelyak system (wind direction and zenith magnitude per second squared).

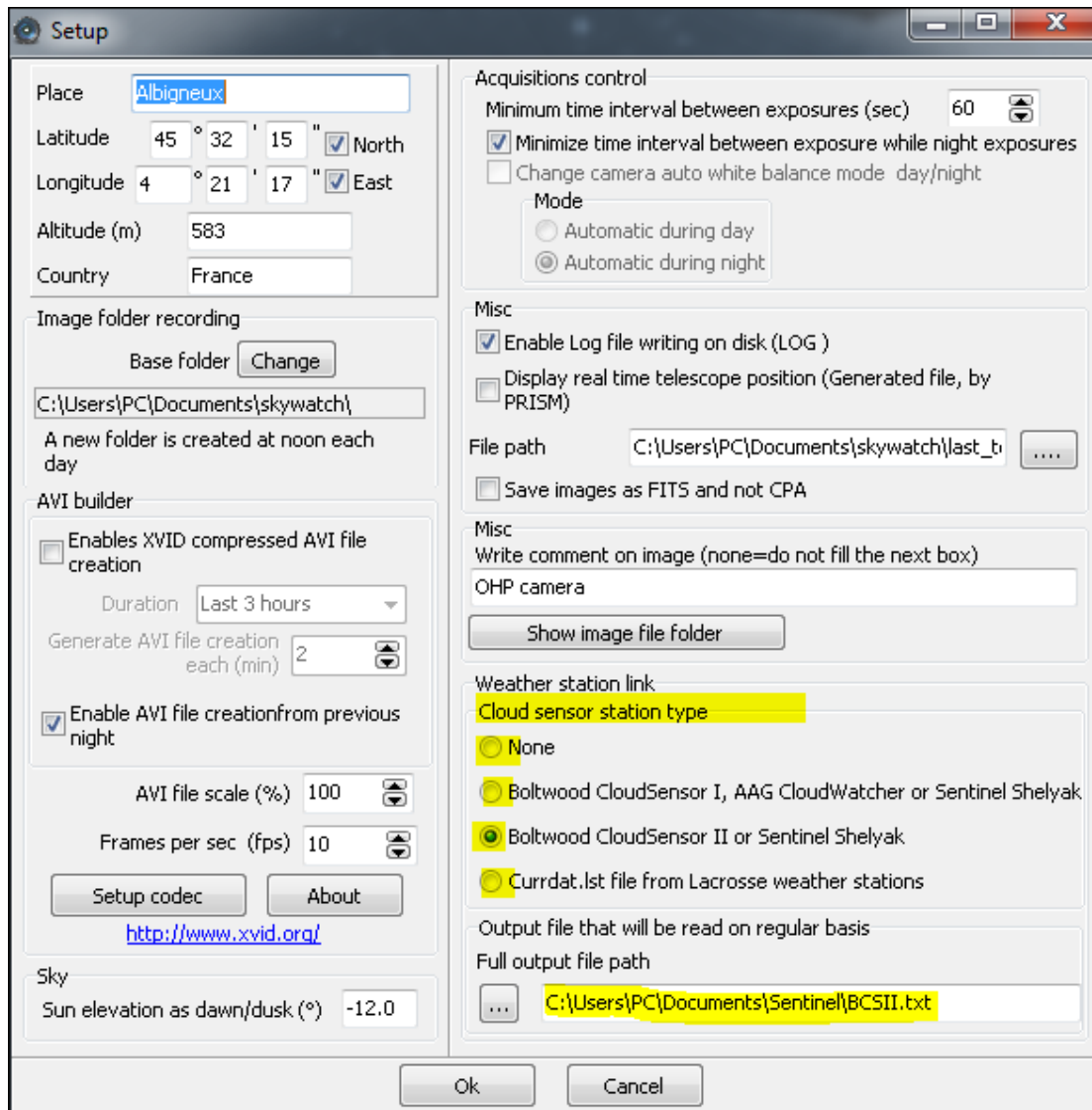

Fig. 80 Group information to provide to connect with cloud sensor system control software.

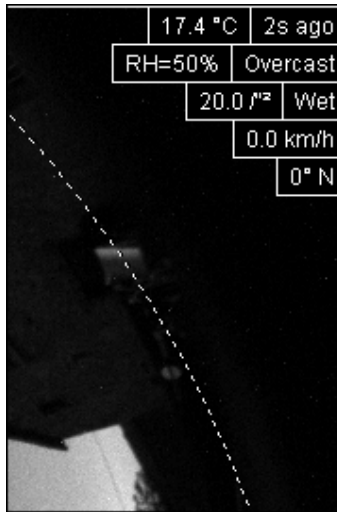

Fig. 81 List of information coming from Sentinel or Boltwood cloud sensor included in the image

3.7 Magnitude per square second display image mode

The software allows the calculation of radiometric magnitude per square second across the sky. It works on color and monochrome cameras. In case of color image, only green pixels will be considered (50%). To do so, you have to open this tab:

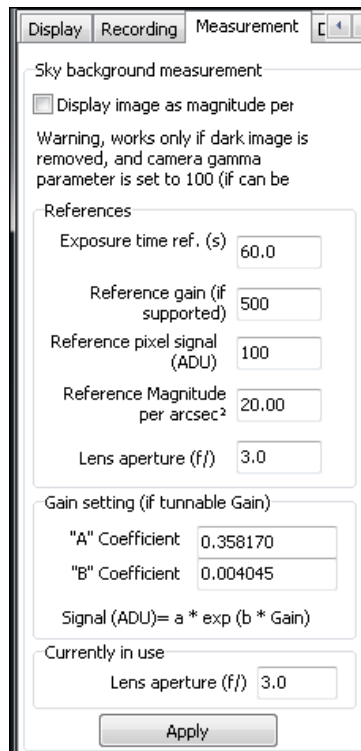

Fig. 82 Tab used to set magnitude image mode display

The calculation is based on a reference image, with reference parameters. To perform this, a reference image is achieved with:

- An exposure time reference

- A camera gain reference
- Opening aperture reference (which is usually fixed as the aperture setting is not accessible).
- Subtracting the reference image by a master dark frame
- The camera gamma adjustment must be set to 100.
- Avoid the presence of Milky Way overhead.
- Save reference image as CPA / FITS

Using this reference image, the signal is expressed as ADU. Nearby zenith the signal is measured and is reduced to a pixel, and must be entered in the panel from figure (Fig. 83) “**Reference pixel signal**” field. It is advisable to use image processing software (such as Prism or equivalent).

At the time of reference image acquisition (during night), using a sky meter measuring device such as Sentinel or SkyQualityMeter (Unihedron), the magnitude per square second will be retrieved and entered as a reference “**Reference Magnitude per arcsec²**”.

The coefficients "A" (0358) and "B" (0.004045) are specific to the camera law gain and might remain at their default values above, but can be re-calibrated in laboratory for a specific camera.

Once the calibration parameters known, the software calculates the magnitudes map per square second from the last image grabbed from the camera. Median filtering is performed to remove most of the stars. The image pixels are expressed in magnitude per square second, a false-color palette is applied and a color scale indicates the color to magnitude correlation.

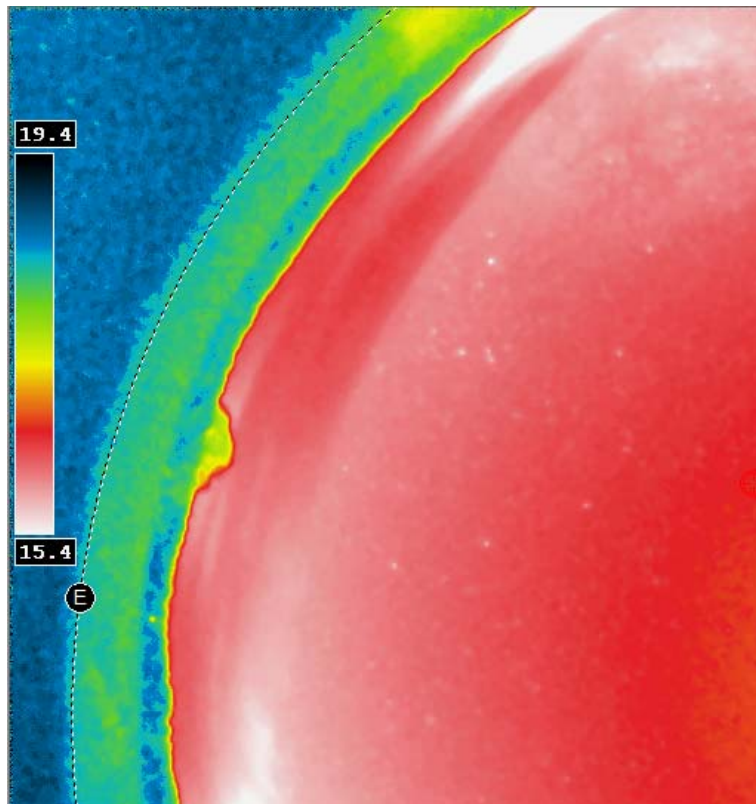

Fig. 84 Map of the sky expressed as magnitudes per arcsec square with false colors.

3.8 Telescope control software link

Telescope's pointing direction can be display and embedded to the last all Sky Image. The telescope pointing software shall be able to generate a simple text file, containing date and time of the measured position and equinox 2000 RA/DEC coming from the telescope current position.

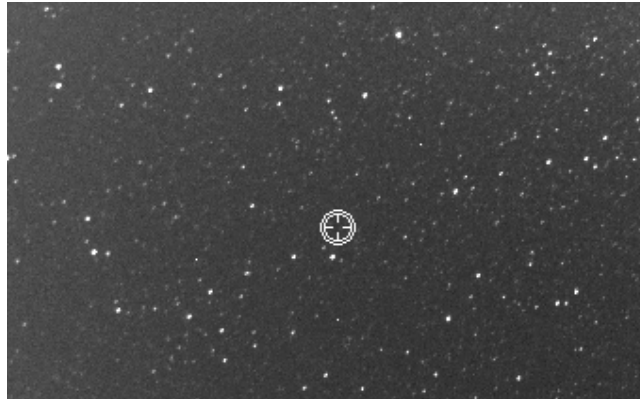

Fig. 85 Current telescope position merged to the last all Sky image

If the time gap between the current date and the date of the last telescope position is greater than 10s, the telescope's cross position switches to red color, indicating that the position is no longer refreshed by the software, and thus might not be valid.

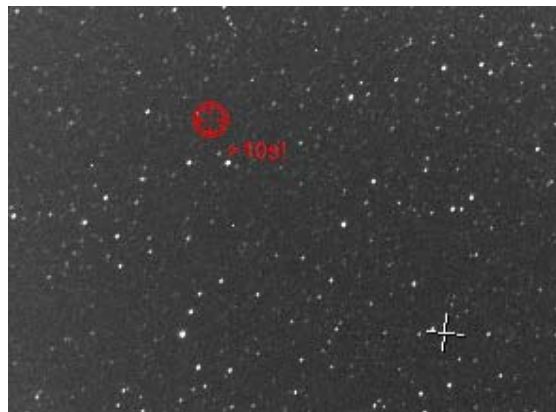

Fig. 86 Telescope position as red because current date and telescope position date is larger than 10s

Here is the file format used to read telescope position as ASCII file, 1st line is amount of days since Dec 31st 1899 at 12 o'clock, the second line is RA as radian, the third line is DEC as radian:

```
40307.9796818056
4.3461698620
0.9539777407
UTTime = 09/05/2010 11:30:44 p.m.
RA2000 = 16h36m04.126s
DEC2000 = +54°39'32.03''
```

The other remaining lines are not read and are just provided for information.

3.9 Star count for cloud coverage estimation

During the night, the software is able to extract stars, and count them up. Thresholds can be applied to define what is regarded as clear skies, or mid overcast skies. The software output this data either into a text file, or uses a COM interface that can be used by other any software.

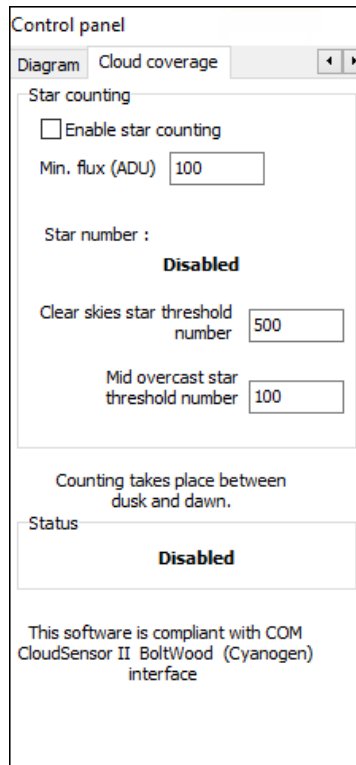

Fig. 87

Star extracted are plotted into the image.

3.10 24h overview

This can be reached by activating this tab:



Fig. 88

During the course of the time, the software picks an image stripe located at the center of the fisheye field, and duplicates it into another image that has the same height of the previous image, but this stripe is shifted according to the time, and build up a global image where X axis depicts time.

It allows the user to see how the sky has changed during the course of the time, in a single glance. In the image sample, it can be noticed that the end of the night was not clear and the star to disappear under a thin layer of clouds. It goes over the left side of the image on next noon.

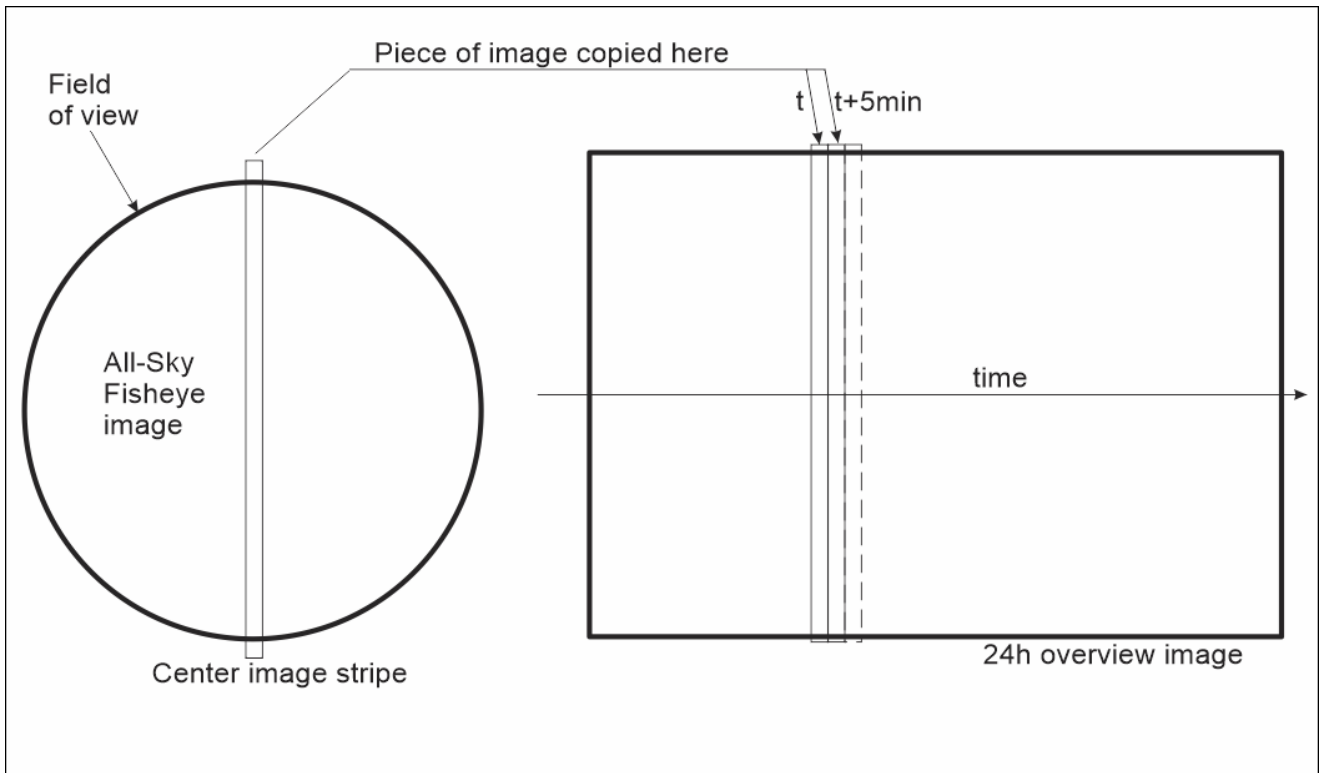

Fig. 89 : 24h image overview construction scheme

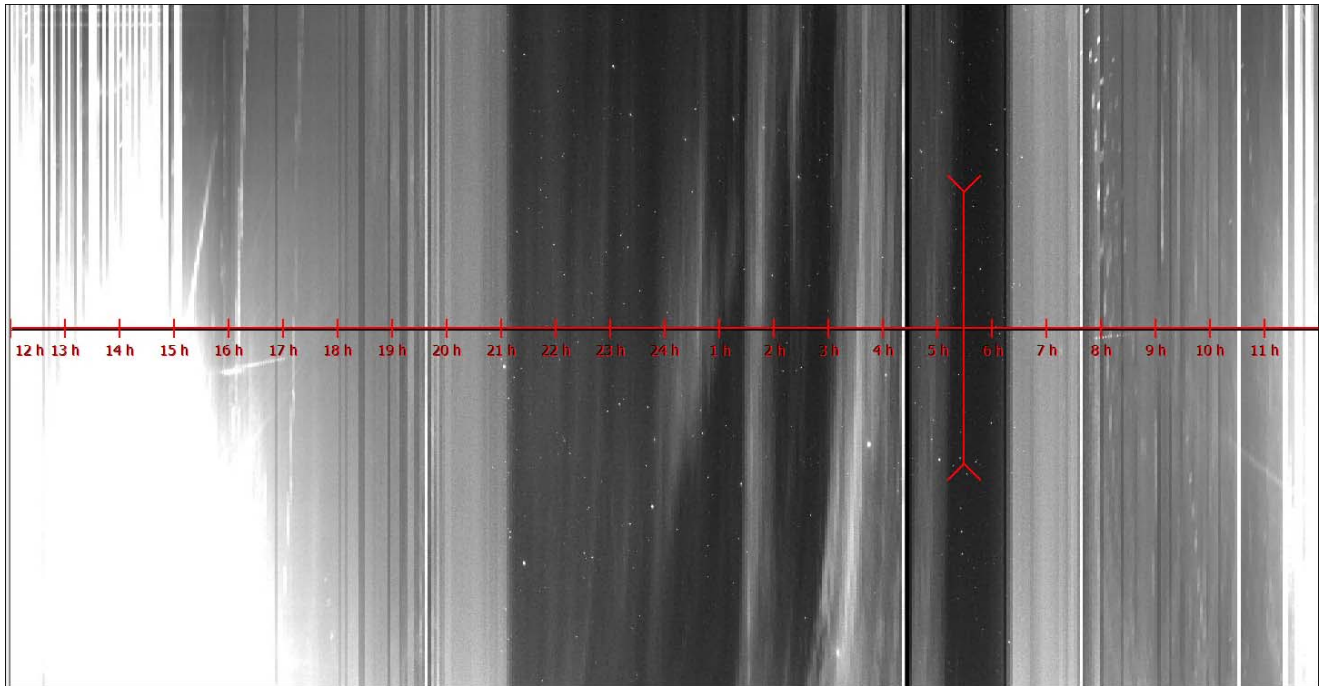

Fig. 90 : Resulting image

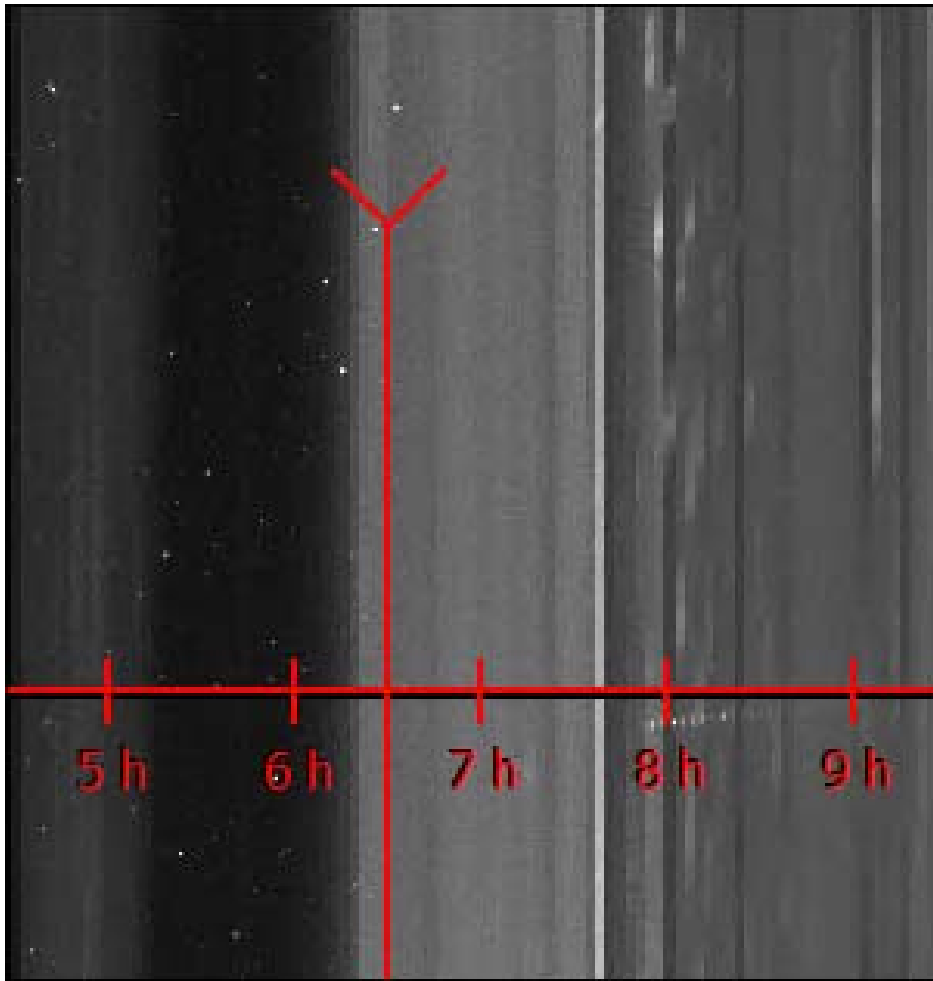

Fig. 91 : Previous image zoom to the end of the night, star are visible then sky clear up with dawn.

4 Sphere condensation heater management

4.1 Introduction

The heating of the sphere is achieved throughout a set of resistors placed under the sphere base. It can defog or defrost the outside side of the acrylic sphere.

The system is autonomous (works without link to PC and without user's supervision). It sets out the conditions when temperature and humidity levels enable occurrence of water condensation.

As soon as the temperature is below a certain value, and moisture above another value, the heating system is automatically activated. These levels are named **temperature and humidity levels**.

By default, factory set, the default threshold temperature is set to +7 ° C and humidity level to 90%. These thresholds may be inappropriate for a given site and can be adjusted by user input (RS 232 link to camera is mandatory to do so).

Similarly, the heating power is set by default to 50%, it can be changed according to site and circumstances.

4.2 Adjusting and start-up

Use the menu "**Options / Dome Heating Control...**" from the camera software main's menu.

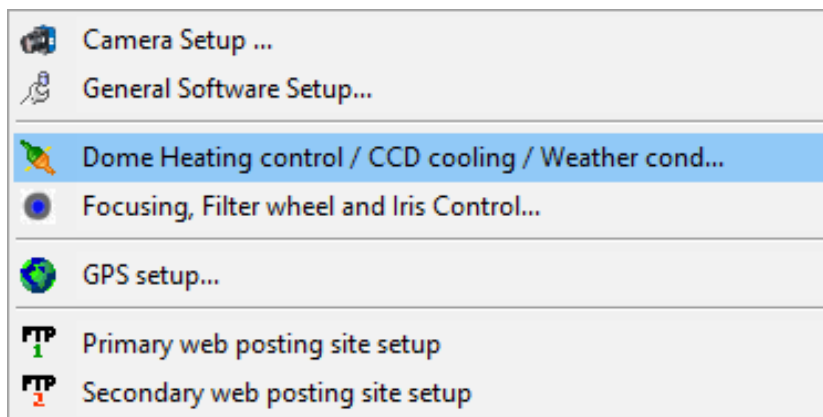

Fig. 92

Once connected, the following window appears:

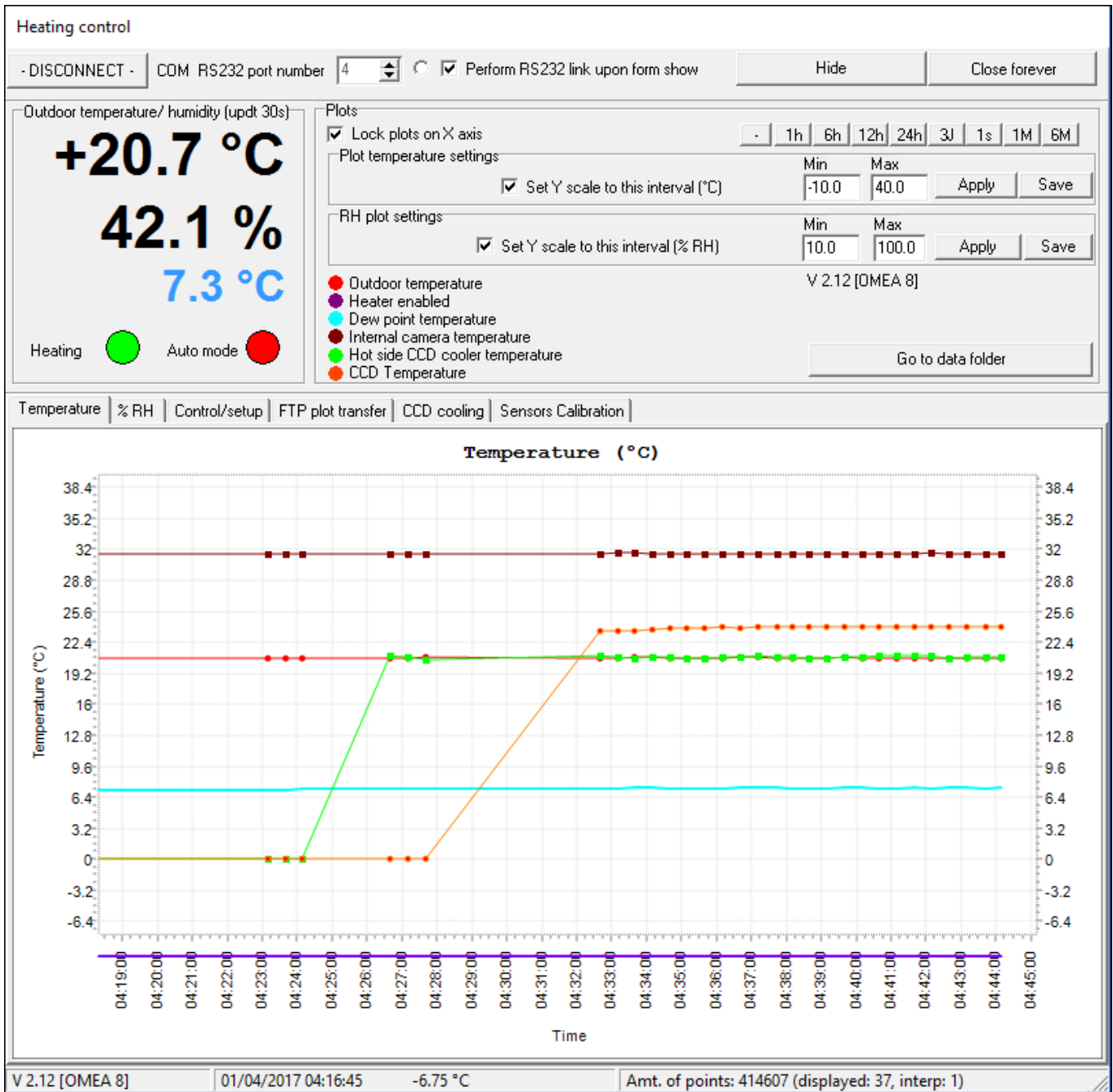

Fig. 93 Temperature curves

It provides outdoor temperature, camera temperature, outdoor humidity and dew point (light blue). The software records the data and curves are constructed progressively (if connected to the PC all the time).

Beware, if this window is closed, recording data cannot occur anymore. We recommend that you simply hide it. Nevertheless, heater activation is achieved by the camera alone without any link to the PC.

The red curve provides outdoor temperature, light blue curve is dew point, and purple indicates the status of heating: no heating when the plot is overlapping the X axis, and heating is enabled when it is up.

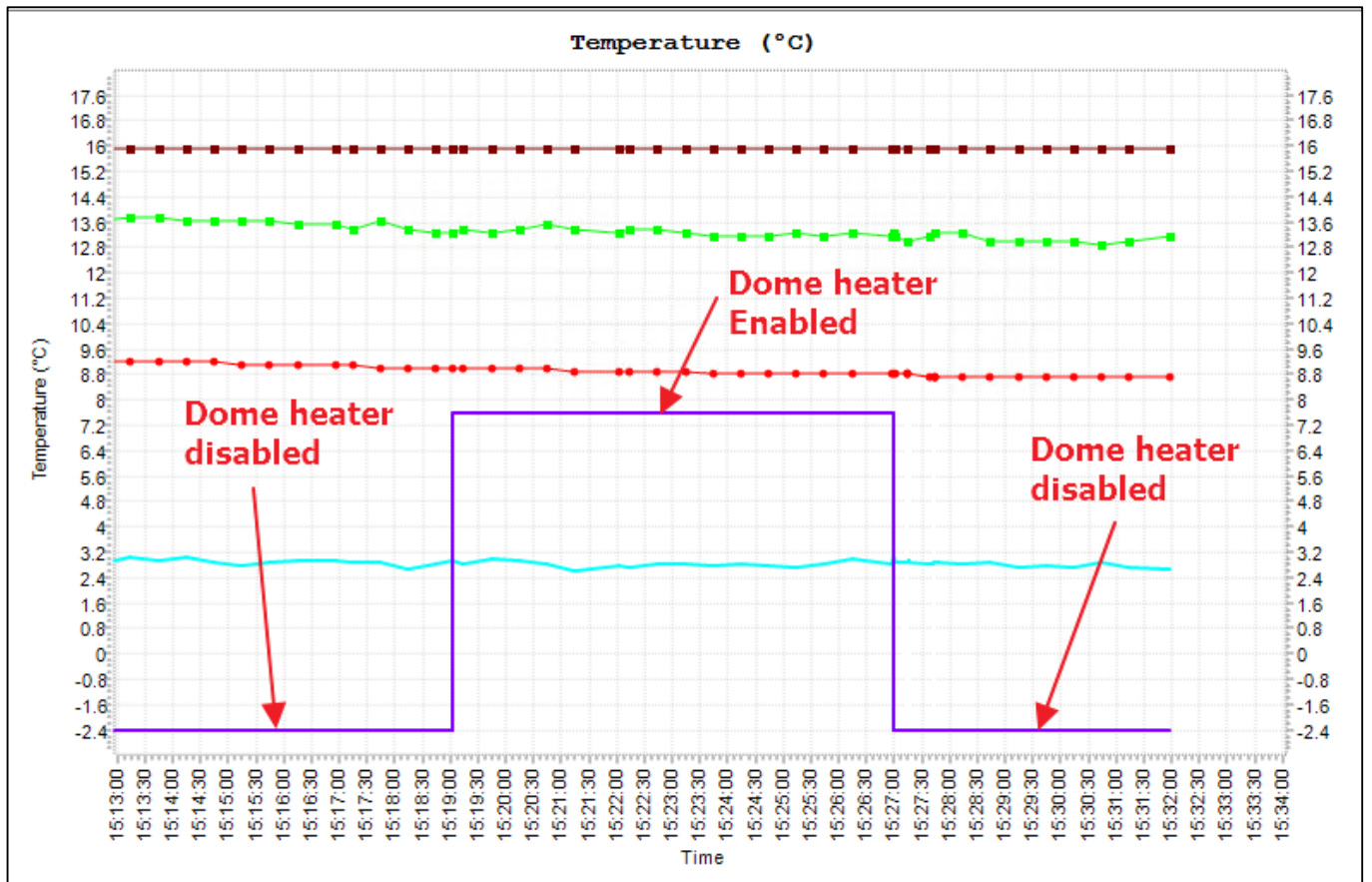

Fig. 94 Heating plot (as purple) warning there is not unit bound to it

The tab "% RH" provides access to humidity plot expressed as % RH (Relative Humidity). Outdoor temperature and humidity is measured by the external probe, and is used to trigger the dome heating.

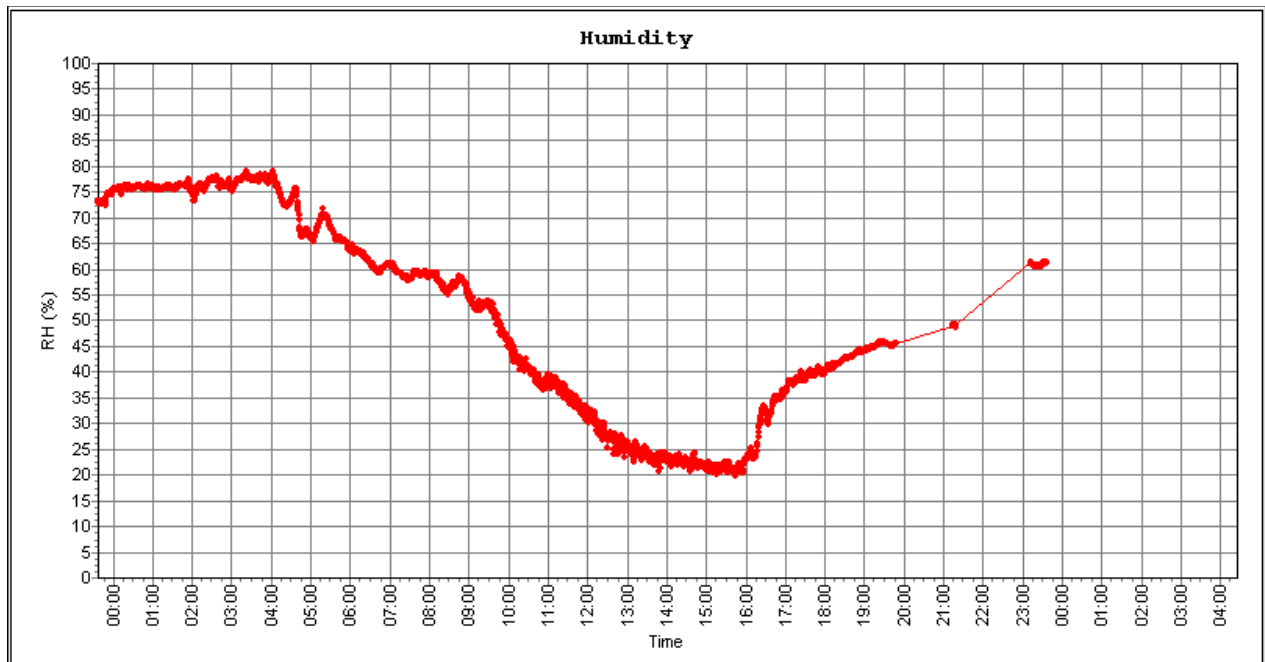

Fig. 95 Relative humidity plot

The next plot shows as red the external camera humidity, and the marron plot is the internal caùera humidity. The internal humidity shall be kept under 20% RH. The camera embeds a desiccant (molecular sieve) inside it, to have the humidity as low as possible, to prevent dew from forming in the inner side of the dome. **So do not dismount the backside of the camera if not needed, this would cancel out the effect of the desiccant, and humidity level would be higher than 20% RH.**

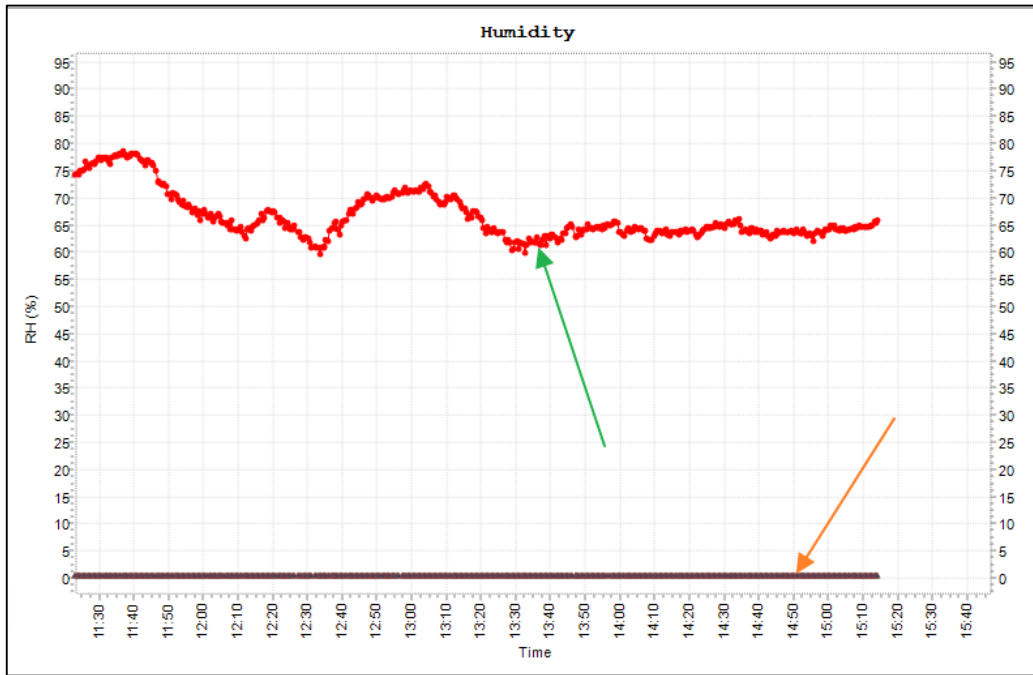

Fig. 96 Relative humidity plot, the orange arrow shows the inner humidity level of the camera. Here close to zero on a brand-new camera with fresh desiccant.

The tab **"Control/Setup"** sets the temperature and the humidity threshold levels that will trigger sphere heating start up. The power level to be used can also be set by user to get better efficiency. Once these parameters are set, do not forget that you need to send/write them to the camera.

| Auto temperature / humidity setup | | Controls | |
|--|--------------------|---|-----------|
| Temperature threshold (°C) | 14.0 Ts | <input checked="" type="checkbox"/> Automatic heater mode | |
| If outdoor temperature is less than Ts and if outdoor humidity is higher than Rh _s , heating will startup (heating in auto. mode) | | <input type="checkbox"/> Force heater | |
| Humidity (%RH) | 75 Rh _s | <input type="checkbox"/> Poll system each second | |
| Power Max (%) | 80 14.4 W | Humidity sensor parameters | |
| If outdoor temperature is higher than Ts+2°C and if outdoor humidity is lower than Rh _s -5%, heating will shutdown. | | Gain (ADU/65535) | 141.00000 |
| <input type="button" value="Update camera"/> | | Offset (ADU/65535) | 0.15150 |
| | | <input type="button" value="Apply"/> | |

Fig. 97 Setup and control panel

This controls allow the heater to switch to automatic mode (**"Automatic heater mode"** stand-alone or PC-free mode) or **"Force Heater"** as manual mode in this case uncheck the **"Automatic heater mode"**.

Humidity sensor calibration is also possible (gain/offset).

Finally, it is possible to transfer these plots to website for remote control.

User account

| | |
|--------------------|--------------------|
| Host or IP address | ftp.astrosurf.com |
| User/login | cavadore |
| Password | •••••• |
| Remote folder | /www/meteo/current |

Humidity (%RH)

Update interval (Minutes)

Enable image posting using FTP

Fig. 98 Website setting for temperature and humidity plot posting

5 Weather measurement module

A weather module can be attached to the camera (optional). It consists into an external box that is attached to the camera and includes:

- Measurement of the ambient temperature
- Measurement of the ambient relative humidity
- Measurement of the Pressure (Mbar)
- Measurement of the wind speed
- Measurement of the wind direction



Fig. 99 *Wind speed and Wind direction sensor*

The next picture shows different part of the weather module:

- Relative Humidity and temperature module
- Cable going to the ALL-SKY camera
- 25m cable going to the wind speed and wind direction sensors

The 4 screws (green arrows), holding the top cover of the box can be unscrewed. The hole underneath them, allow using other screws in order to attach the box to a support. Then put back, the cover again. Important, despite this is a water tight box, the box must be always oriented with the vertical direction as depicted below otherwise water may ingress into the box and damage the electronic board inside. There is a small hole underneath the box to sense the atmospheric pressure. It is better to put the box and the RH/Temp sensor in permanent shadow, protected from direct SUN rays.

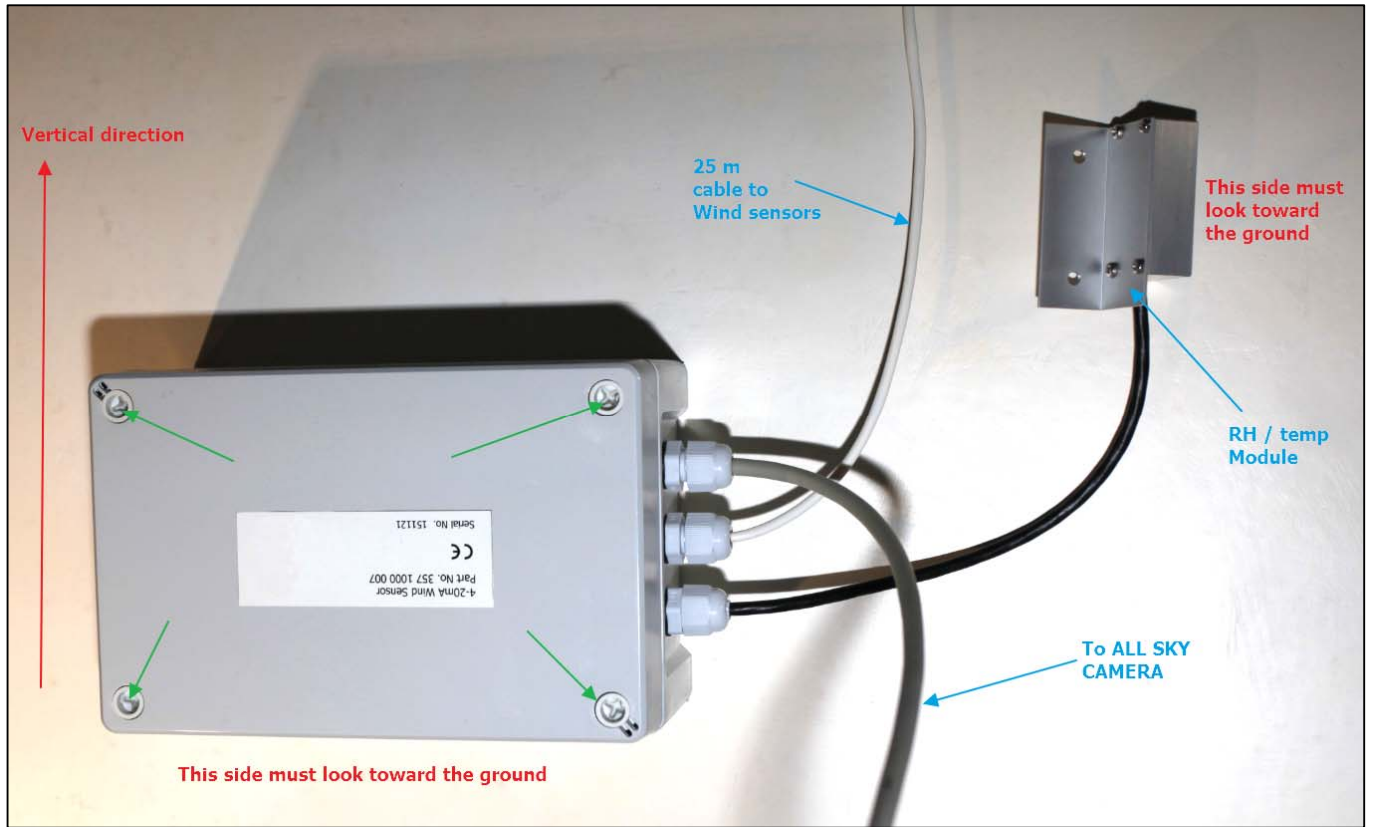

Fig. 100 Sensors control box

The wind sensor must be installed into a mast that is at least 5 m from the ground (10m is better). A system to clamp the wind sensors to the mast is provided. Orientate the wind direction to the north, and put the sensor horizontally.

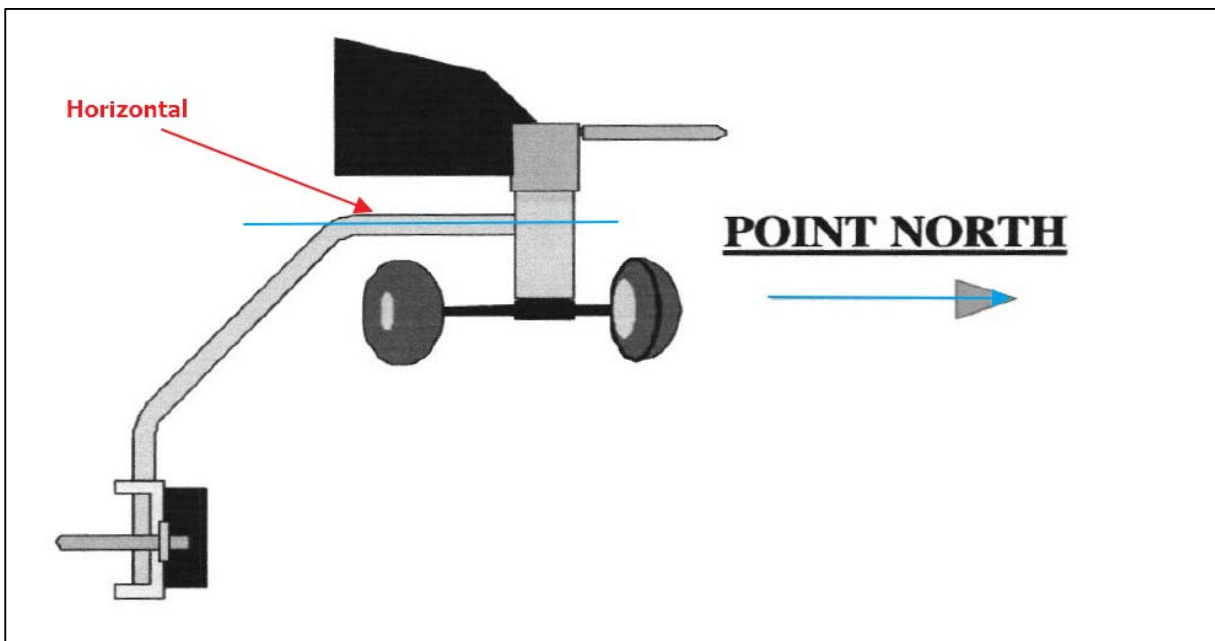

Fig. 101 Wind-sensor orientation

5.1 Sensors software management

Click **“Options/Dome Heating control/ Camera cooling / Weather cond.”** It will bring up the usual sensor panels with plots. Select the appropriate COM port.

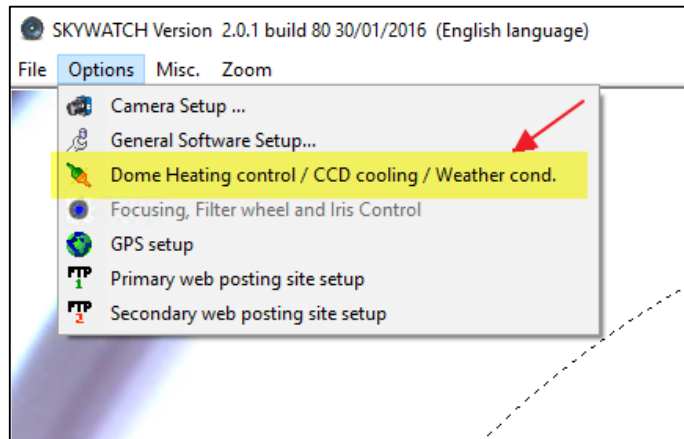

Fig. 102 Menu

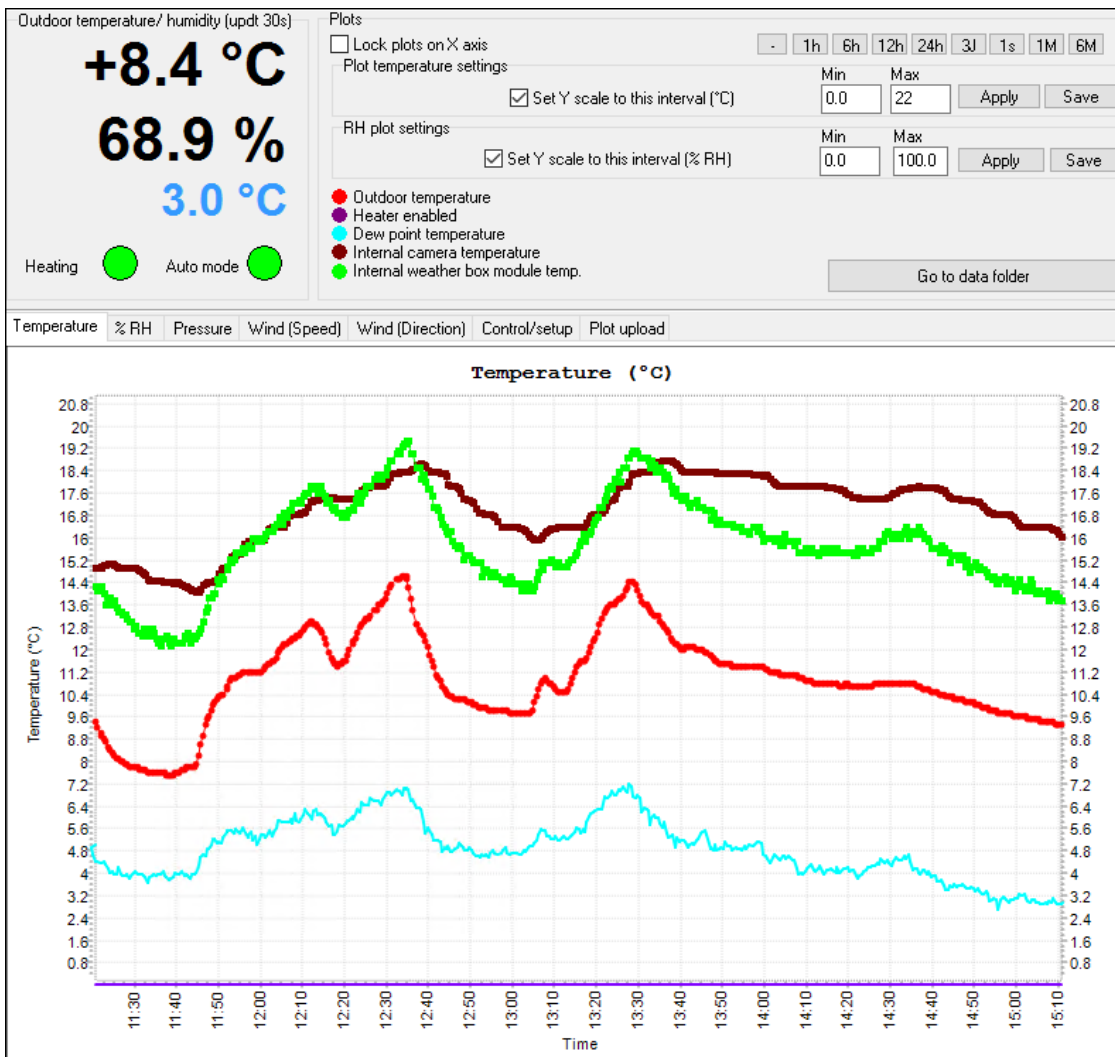

Fig. 103 Temperature from the different sensor of the camera. Red is external temperature, brown is internal camera temperature, green is weather box internal temperature, and cyan is the dew point temperature.

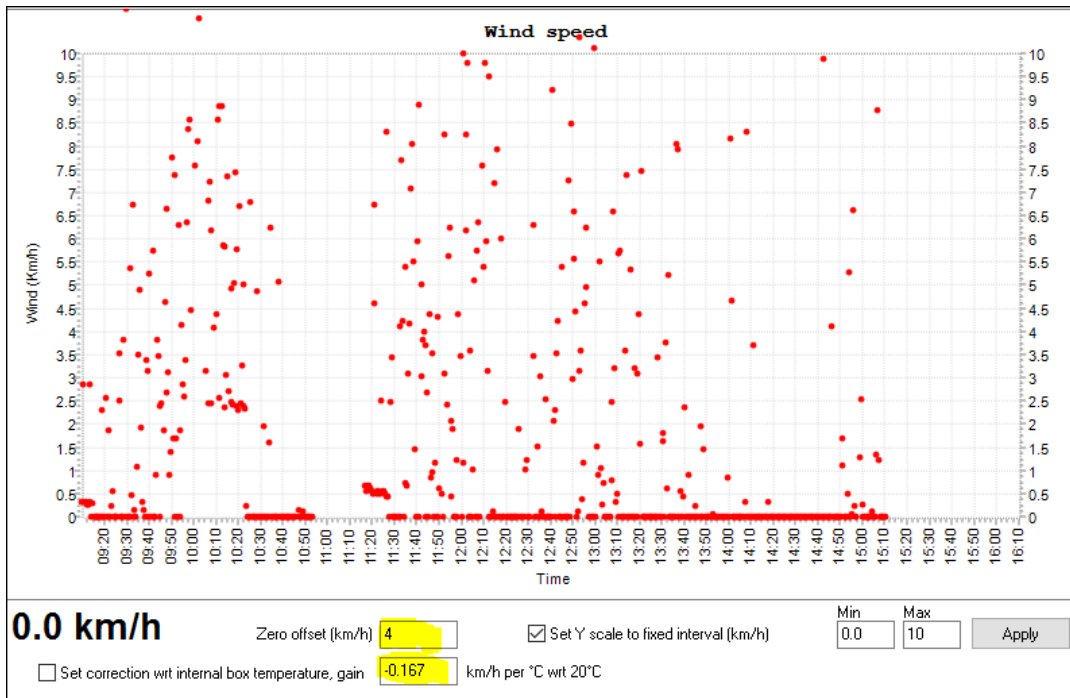

Fig. 104 Wind speed plot

The wind speed raw data can be offset by some figure, because the electronic has a small offset when the wind speed is zero. Also, the measurement can be corrected from some drift induced by temperature changes inside the weather box. The formula used is:

$$\text{Wind_speed} = (\text{Raw_wind_speed} - (\text{InternalBoxTemperature} - 20.0) * \text{Correction_factor}) - \text{Offset}$$

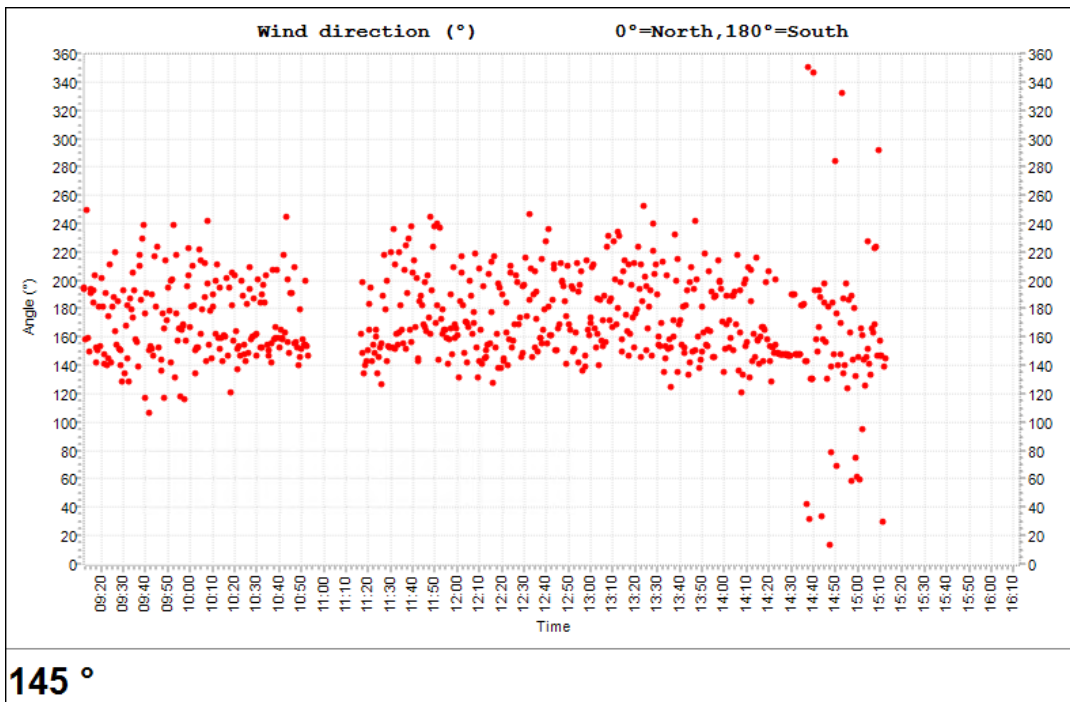

Fig. 105 Wind direction plot

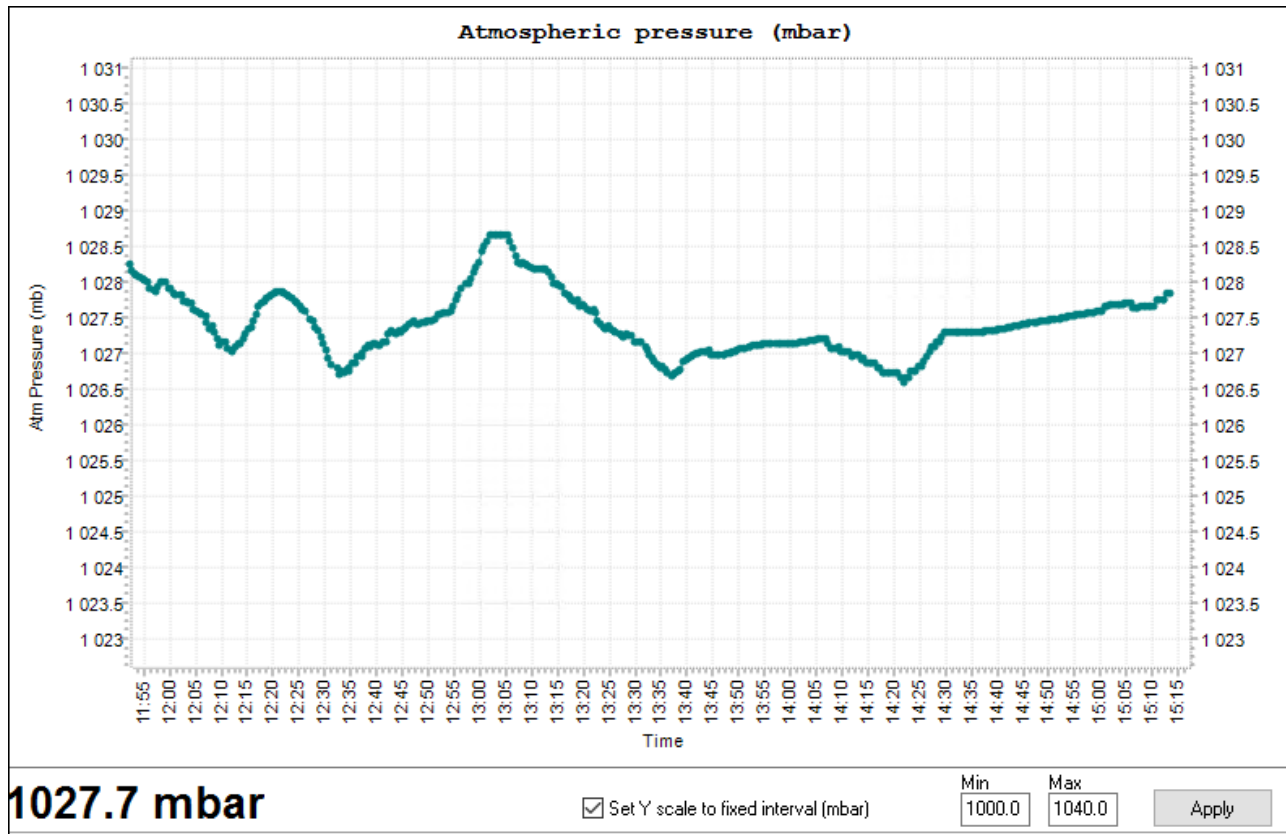

Fig. 106 Atmospheric Pressure

The pressure is corrected to the sea-level, because the software knows all the parameters to carry out the computation.

WARNING: never disconnect/connect the seven-pin connector attached to the camera while the latter is powered. This can lead to false measurements (i.e., temperature set to +104°C!). To regain proper measurements, reconnect this cable, and power cycle (OFF/ON) the camera for 30s in order to get proper measurements.

Avoid to touch with fingers the 7 pins of the connector that drives the digital signal from the module.

5.2 Sensor specifications and operating range

| Sensor type | Min value | Max value | Resolution | Absolute Accuracy |
|----------------------------|-----------|-----------|------------|-------------------|
| Wind speed | 0 m/s | 50 m/s | 0.012 m/s | +/- 3% |
| Wind direction | 0° | 360° | 0.1° | +/- 5% |
| Pressure | 40 kPa | 115 kPa | 0.073 kPa | +/- 1.2 kPa |
| External relative humidity | 0 % | 100 % | 0.03 % | +/- 1 % |
| External temperature | - 40 °C | 100 °C | 0.05 °C | +/- 0.35 °C |

6 Camera maintenance

6.1 Sphere cleaning

Sphere cleaning must be achieved on regular basis. Rains can bring dust that is deposited on the sphere surface; it reduces the optical transmission and image quality.

The acrylic sphere outer and inner surface can be cleaned with water, then with a Kleenex moistened with washer fluid dedicated for window cleaning. The 8 screws can be removed to detach the sphere from the rest of the camera. Attention must be paid on these topics:

- The cable bringing power to the heaters should not be pinched during reassembly
- O-rings properly positioned in their grooves
- The distance between the sphere support and the camera body must be at least 0.7mm and constant around the perimeter.
- 8 screws must be put together with their washer and all tightened the same way.

Incorrect reassembly can cause loss of sealing, allowing rain to enter and de facto guarantees no longer apply. If you feel confident with dismounting sphere, please do not do it.

6.2 Camera internal desiccant replacement

Inside the camera, a small desiccant bag has been installed. This is molecular sieve that can set the level of humidity down to zero. Replacement of this bag, may happen once every 3 years. The inside camera relative humidity can be monitored, if above 60% inside the camera, this latter should be inspected for leaks.

7 Trouble shooting

This section aims at providing hints to solve issues.

7.1 Camera does not deliver images

The USB port driver might be outdated, please update USB port driver. Also change USB port on your PC, sometime some USB are slightly damaged (ESD) with the course of the time.

If the issue persists, please contact us, the long 20 m USB extender cable might be also damaged, check that no damage has occurred on this cable (no small animal has started to eat the USB cable for instance, or lightening has not hit the camera).

This document below will help you to figure out in details the issue and to solve it :

https://www.alcor-system.com/common/allSky/docs/Troubleshoot_camera_not_delivering_images.pdf

7.2 Camera disconnects when heating is active

There is a grounding issue with the camera, the PC and the mains' AC power supply. To fix the issue there are two options: the camera earth connected (option #1) or the power supply floating option (option #2). Please proceed as below (select the best scheme for you) and this issue will be resolved. One has to keep in mind that there is a link from the camera to the PC via USB cable that has shield connected to its GND. Ground loop can occur, and finding the best grounding scheme can depend on the place, and the way your installations is earthed. This issue will not arise with camera sold after 01/01/2023 where power supply has a 2 pin C8 main AC cord where earth pin does not exist.

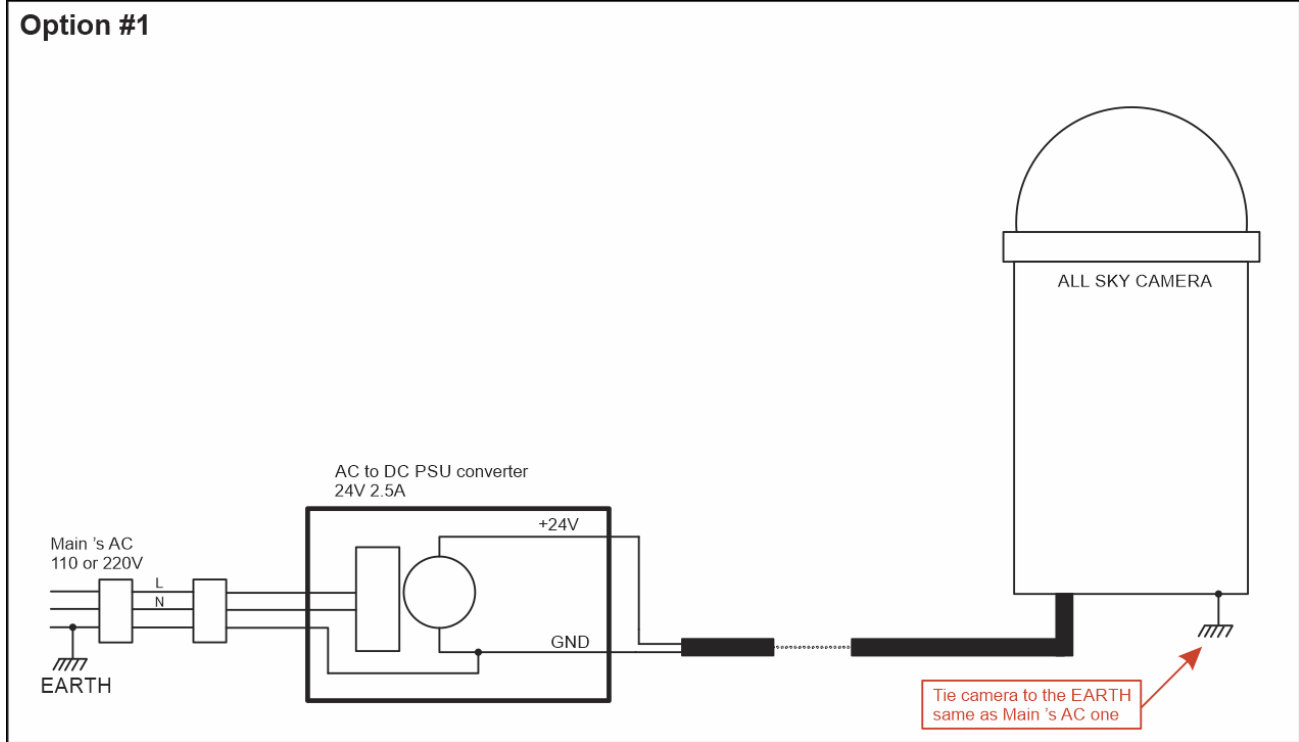

Fig. 107 System grounding scheme (Option 1)

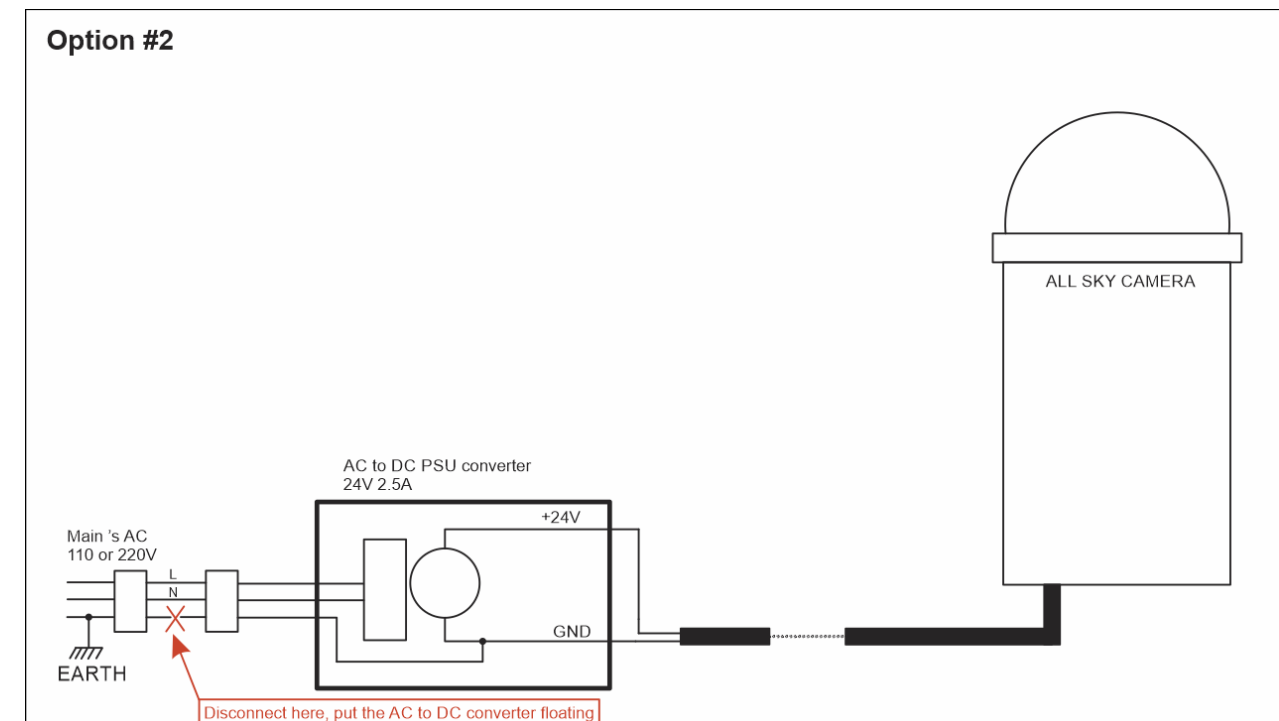

Fig. 108 System grounding scheme (Option 2)

7.3 Dew inside the dome

This may happen after several year of operation, if the internal desiccant is exhausted. Please check the internal humidity figure. It should be less than 20%, above 60% dew can form easily. To replace the internal desiccant, please contact us to get the procedure.

8 Product terms of use

The use of this product is solely for monitoring the sky, night and day, entertaining, educational or scientific purposes.

Use of this product involving people's lives is the responsibility of the user and in no way ALCOR SYSTEM will be held liable for injuries to persons or property theft as the use of this camera described in this manual.

---00---